



An Coimisiún um
Rialáil Cumarsáide
Commission for
Communications Regulation

Site Survey Methodology

Programme of Measurement of Non-Ionising Radiation

Site Survey Methodology

Reference: ComReg 08/51R4

Date: 25/09/2020

An Coimisiún um Rialáil Cumarsáide
Commission for Communications Regulation

1 Lárcheantar na nDugaí, Sráid na nGildeanna, BÁC 1, Éire, D01 E4X0.
One Dockland Central, Guild Street, Dublin 1, Ireland, D01 E4X0.
Teil | Tel +353 1 804 9600 Suíomh | Web www.comreg.ie

Document Revision History

Document Version	Date	Nature of Revision
08/51R4	23 rd September 2020	Updating of general methodology principles to coincide with updates ICNIRP guidelines released in March 2020.
08/51R3	28 th March 2017	<p>Addition of table defining the boundaries of electromagnetic field regions and summarising region characteristics</p> <p>Updating of bands to be surveyed for frequency selective measurements</p> <p>Addition of method for measuring TDD LTE signals</p> <p>Deletion of method for measuring analogue PAL TV due to obsolescence of the technology</p>
08/51R2	24 th January 2014	<p>Methods for measuring emissions from new technologies: LTE, WiMAX</p> <p>Updated methods for measuring WiFi and Radar</p> <p>Addition of general measurement principles</p> <p>Updating of bands to be surveyed for frequency selective measurements</p> <p>Miscellaneous updates to previous measurement methods</p>
08/51R	15 th July 2009	<p>Methods for measuring noise & UMTS TDD</p> <p>Extension of FWALA bands to be measured</p>

08/51	1 st July 2008	Original Document
-------	---------------------------	-------------------

Content

Section	Page
1 Introduction.....	6
2 Terms and Definitions	8
3 Survey Stages – Overall Survey Procedures.....	10
3.1 Initial Site Survey	10
3.2 Broadband Measurements.....	10
3.3 Frequency Selective Measurements.....	11
4 Measurement of Electromagnetic Fields.....	12
4.1 Measurement in the Far Field and Radiating Near Field.....	13
4.2 Measurement in the Reactive Near-Field.....	13
5 Frequency Selective Measurements – General Procedures	15
5.1 Measurement Equipment.....	15
5.2 Bands for Frequency Selective Measurement.....	17
5.3 Measurement Procedure.....	22
6 Measurement Analysis	25
6.1 Broadband Measurements.....	25
6.2 Frequency Selective Measurements	25
7 Reporting Measurement Results.....	27
8 Frequency Selective Measurements -Specific Procedures by Signal / Emission Type.....	29
8.1 PMR.....	29
8.2 FM Radio for Broadcasting.....	30
8.3 T-DAB	31
8.4 TETRA	32
8.5 DVB-T	36
8.6 GSM.....	37
8.7 UMTS.....	42
8.8 LTE	51

8.9 WIFI 77

8.10 WiMax and Broadband Wireless Access (BWA) 88

8.11 Radar 99

8.12 Noise 108

8.13 Other Signals – General Measurement Principles 111

9 Appendices 115

1 Introduction

1. The Commission for Communications Regulation (ComReg) is the licensing authority for the use of the radio frequency spectrum in Ireland.
2. It is a condition of a General Authorisation for the provision of an electronic communications network and/or service as well as of various Wireless Telegraphy licences issued by ComReg that authorised/licensed operators must ensure that non-ionising radiation (NIR) emissions from each transmitter operated under the authorisation or licence must be within the limits set down in the guidelines published by the International Commission on Non-Ionizing Radiation Protection (ICNIRP). Levels of NIR emissions from a licensed transmitter must not exceed the ICNIRP limits in any part of the site or surrounding area to which the general public has access.
3. Since 2003, in order to assess compliance with conditions relating to general public exposure to NIR, ComReg has arranged for NIR surveys to be conducted near a sample number of authorised/licensed transmitter sites nationwide each year. Each survey involves measurement and recording of NIR emission levels at the point of highest emissions (in a public area) associated with the transmitter and a subsequent comparison of the levels with the ICNIRP Limits. All measurements and analysis are then documented in a comprehensive technical report.
4. Arising from the publication of the revised ICNIRP guidelines in March 2020 there is a requirement for ComReg to publish a Revised Site Survey Measurements Methodology to take account of same.
5. The current ICNIRP limits are set out in two documents available at the ICNIRP website [\[1\]](#) and [\[2\]](#). The most recent ICNIRP guidelines [\[1\]](#) for limiting exposure to electromagnetic fields (100 KHz TO 300 GHz) was published on 11 March 2020. The same exposure limits apply whatever technologies emit the non-ionising radiation.

6. This document outlines the updated methodology to be employed by ComReg for the conduct of NIR surveys and replaces the previous version of the methodology (ComReg 08/51R3) published on 28th March 2017. The methodology incorporates many of the measurement methods and procedures outlined in ECC Recommendation (02)04 and CENELEC measurement standard EN 50492:2008/A1:2014, as well as measurement techniques developed by IMST¹ and the EM-Institut² on behalf of the German Federal Office for Radiation Protection.
7. ComReg reserves the right to amend and update this methodology from time to time in order to establish appropriate techniques for measuring emissions from new forms of wireless technology and to incorporate any relevant advances in measurement technology and survey methods.

¹ Institut für Mobil- und Satellitenfunktechnik (IMST) GmbH, Kamp-Lintfort, Germany

² EM-Institut GmbH, Regensburg, Germany

2 Terms and Definitions

Reference Levels

8. These are the Reference Levels for General Public Exposure specified in the relevant ICNIRP guidelines for limiting exposure to electromagnetic fields up to 300 GHz. The current relevant ICNIRP guidelines are:
 - (1) “Guidelines for Limiting Exposure to Time-Varying Electric and Magnetic Fields (1 Hz - 100 kHz)”, International Commission on Non-Ionizing Radiation Protection, Published in Health Physics 99(6):818-836; 2010. <https://www.icnirp.org/cms/upload/publications/ICNIRPLFgdl.pdf>; and
 - (2) “Guidelines for Limiting Exposure to Electromagnetic Fields (100 kHz to 300 GHz)”, International Commission on Non-Ionizing Radiation Protection, Published in Health Physics. 118(5):483-524, 2020. <https://www.icnirp.org/cms/upload/publications/ICNIRPrfgdl2020.pdf>
9. Measurements below the Reference Levels guarantee that basic restrictions for exposure, as set out in the ICNIRP guidelines, are not exceeded. Measured and adjusted levels are compared against the Reference Levels.

Designated Transmitter Site

10. The transmitter site which has been chosen for survey in order to assess compliance with the Reference Levels of NIR emissions from antennas located at the site.

Measurement Point

11. The position where the survey antennas and probes are mounted (i.e. on a suitable stand or tripod). This point represents the location of the maximum field strength, attributable to the antennas at the designated transmitter site, to which a member of the public might be subjected.

Measured Level

12. The physical magnitude of an electromagnetic emission determined using measurement equipment. Expressed in Volts per metre (V/m) for electric field strength, and in Amperes per metre (A/m) for magnetic field strength.

Adjusted Level

13. In the case of some emission types an adjusted level is calculated from the measured electric field level for any or all of the following reasons:

- (1) to correct for a spectrum analyser measurement bandwidth which is less than the signal bandwidth;
- (2) to extrapolate to an estimate of the level of emissions from a transmitter under maximum traffic conditions or at a maximum duty cycle;
- (3) to account for the characteristics of certain complex signal types.

Total Exposure Quotients

14. The Total Exposure Quotients³ are calculated in order to assess simultaneous exposure to multiple frequency fields in respect of electrical stimulation effects and/or thermal effects as appropriate. The calculation of the quotient values is defined in the ICNIRP Guidelines.

³ See Appendix 2

3 Survey Stages – Overall Survey Procedures

Surveys must be conducted in three stages as follows:

3.1 Initial Site Survey

15. At all sites surveyed, an initial investigation is to be carried out using a field strength meter with an isotropic field probe (appropriate to the frequency range of emissions from the site) to find the location of the maximum field strength. This will be the measurement point for the next two stages of the survey.
16. In the case of designated transmitters sites where emissions occur in bands for which isotropic field probes are not currently available, the measurement point may be selected by means of:
 - (a) a sweep of the area using a spectrum analyser with appropriate antennas;or
 - (b) calculation based on the theoretical propagation from the antennas on the designated transmitter.

3.2 Broadband Measurements

17. Once the location of the maximum field strength has been identified, the field strength meter and isotropic field probe are to be mounted on a non-conductive stand (e.g. a tripod) at the *measurement point* with the probe at a height of 1.5 m above the ground / floor. The field strength meter must have a data logger capable of storing an RMS measurement of at least six minutes, which can be later analysed and included in the measurement report. The aggregate electric or magnetic field strength (in V/m or A/m as appropriate) is to be recorded over a period of at least six minutes. Survey personnel should retreat from the probe during measurements in order not to perturb the electromagnetic field.
18. In the case of *designated transmitter sites* where emissions occur only in bands for which isotropic field probes are not currently available, this stage may be omitted.

3.3 Frequency Selective Measurements

19. Measurements of emissions at specific frequencies are then to be carried out at the *measurement point* using a spectrum analyser and a range of antennas matched to the frequencies of the emissions being measured. The spectrum analyser must be set to sweep each frequency range continuously for a period of up to six minutes and the results must be recorded in the spectrum analyser for later analysis and documentation in the site survey report.
20. Survey personnel should retreat from the antenna during measurements in order not to perturb the electromagnetic field.
21. This procedure is to be repeated at different frequency ranges until the emission levels in all relevant frequency bands have been recorded.
22. The approach to frequency selective measurements is outlined in greater detail in Section 5.

4 Measurement of Electromagnetic Fields

23. Electromagnetic fields can be sub-divided into two components:

(1) Electric field E [measured in Volts per metre or V/m]

(2) Magnetic field H [measured in Amperes per metre or A/m]

24. Around an antenna, electromagnetic fields are divided into three main regions. The boundaries of those regions are defined in Table 1, which also summarises the characteristics of those regions.

Region	Reactive Near Field	Radiating Near Field	Far Field
Region edges, measured from antenna where $\lambda =$ wavelength $D =$ largest dimension of the antenna	$0..max \begin{pmatrix} \lambda \\ D \\ \frac{D^2}{4\lambda} \end{pmatrix}$	$0..max \begin{pmatrix} \lambda \\ D \\ \frac{D^2}{4\lambda} \end{pmatrix} \dots 0..max \begin{pmatrix} 5\lambda \\ 5D \\ \frac{0.6D^2}{\lambda} \end{pmatrix}$	$max \begin{pmatrix} 5\lambda \\ 5D \\ \frac{0.6D^2}{\lambda} \end{pmatrix} \dots \infty$
$E \perp H$	No	Effectively Yes	Yes
$E/H = Z_0$	$\neq Z_0$	$\approx Z_0$	$= Z_0$
Component to be measured	E and H	E or H	E or H

Table 1 - Electromagnetic field regions around an Antenna⁴

⁴ Sources: Bienkowski & Trzaska, 2012, p.18 and EN 50492:2008/A1:2014 p. 13

4.1 Measurement in the Far Field and Radiating Near Field

25. The E-field and the H-field are mathematically interdependent⁵ and the relationship is very predictable in the far field. In the radiating near field the E-field and the H-field are still mathematically interdependent, but the relationship is more complex albeit still predictable. The measurement locations for most transmitter installations lie well within the far field, as the wavelengths of the transmitted signals are relatively short, and the antennas are typically located many metres from any public area. Table 2 shows indicative wavelengths for some commonly transmitted signal types.

Signal Type	Frequency	Wavelength
PMR Low Band VHF	68 MHz	4.41 m
UHF TV	470 MHz	0.64 m
GSM 900 (mobile phone base)	925 MHz	0.32 m
GSM 1800 (mobile phone base)	1805 MHz	0.17 m
UMTS 2100 (mobile phone base)	2110 MHz	0.14 m
5G NR (mobile phone base)	3500 MHz	0.09 m

Table 2 - Indicative wavelengths of some commonly transmitted signal types

26. In the far field and radiating near field only one component needs to be measured, as the other component can be derived from it. Normally it is only the electric field which is measured in these regions.

4.2 Measurement in the Reactive Near-Field

27. In the case of transmitters of very long wavelength signals, such as long wave radio (1.19 km wavelength), the H-field and E-field must be measured separately as the point of measurement will most likely lie within the reactive near-field region. Here, the relationship between E and H becomes very complex and there is no direct correlation between both components of the electromagnetic field.

⁵ $E = H \times Z_0$ where Z_0 (characteristic impedance of free space) = $120\pi \approx 377 \Omega$

28. In cases where emissions are to be measured inside the reactive near field of a transmitter (e.g. when measuring emissions from a long wave transmitter), distinct sensors must be used for each field component. The electric component (E) of the electromagnetic field can be easily measured using suitable antennas, e.g. dipole, bi-conical, log-periodic etc, and the magnetic component (H) of the electromagnetic field is usually measured with loop sensors (as the current induced in the loop is proportional to the magnetic field strength crossing the loop).

5 Frequency Selective Measurements – General Procedures

29. Detailed frequency selective measurements must be conducted at the selected measurement point, in order to identify the individual, transmit frequencies and field strengths of each emission present. The results of the measurements are used to calculate Total Exposure Quotients for simultaneous exposure to multiple frequency fields. Measurements may be conducted by means of scans of the relevant frequency bands with a spectrum analyser.

5.1 Measurement Equipment

Receivers

30. These measurements are most easily carried out using lightweight battery powered spectrum analyser. The spectrum analysers will occasionally be required to operate in hostile RF environments and good dynamic range and inter-modulation performance will be essential for reliable and repeatable results.

31. The spectrum analysers should be capable of software control. Software control is essential due to the vast amount of frequency and amplitude data to be collected during the survey and to maintain consistent results over several sets of survey equipment being operated by several different survey officers. This software should also make provision for the programming of antenna factors and feeder cable insertion loss. This will allow the survey system to use a variety of antennas and cables allowing for a degree of customisation for specific band surveys. In this way human error can be kept to a minimum.

32. The device must be capable of recording and storing in its memory all relevant measurement data⁶ along with all measurement parameters⁷ applied and time and date of measurement. The device should also offer a facility to import data, applied parameters and timestamps for each measurement to a computer for analysis and insertion in graphic form into a measurement report.

⁶ e.g. frequency, measured level

⁷ e.g. trace mode, detector, RBW, VBW, Sweep Time, start frequency, stop frequency

33. Additionally, it should be noted that for a reactive near-field situation both electric and magnetic measurement are required (use of E and H sensors). In the case of some types of emission, especially pulsed signals (e.g. Radar) or signals with potentially long empty time gaps between beacon or signalling symbols/frames (e.g. LTE and WiFi), a spectrum analyser with time domain measurement functions (e.g. zero span) is required to detect and characterise bursts.

Antennas

34. For the frequency selective measurements, antennas should be lightweight and robust, and good quality feeder cables should be used. Preferred types of antennas to be used are:

- (a) Magnetic loop for HF
- (b) Broadband dipole antenna or (encapsulated) log-periodic antenna
- (c) Bi-conical antenna
- (d) Directional antenna such as horn, dish, lens, log-periodic (for emissions above 3 GHz)
- (e) Three-axis (“isotropic”)

35. In the case of emissions in the range 75 MHz to 3 GHz, three-axis (“isotropic”) antennas only must be used, unless otherwise indicated. These antennas are readily available commercially and will capture most commonly occurring emissions (GSM, UMTS, PMR etc.) from all directions, thus giving a fuller picture of the various emissions contributing to the overall electromagnetic field at the measurement point.

36. For lower frequencies, considering the significant wavelength, electrically small antennas should be chosen. Using passive electric antennas, the minimum distance between the antenna and any obstacle (e. g. wall or ground for example) must be at least 1λ .

5.2 Bands for Frequency Selective Measurement

37. At every site, scans of all the bands shown in Table 3 below must be performed in order to determine the presence of emissions. If emissions are present in a band, full frequency selective measurements must be conducted and recorded in the band. The table lists the emission or signal types likely to be found in each band. ComReg reserves the right to specify measurement of emissions in additional bands at any designated transmitter site where those additional bands are used for transmission.

Band Name	Frequency Range (MHz)	Likely Emission/Signal Types in Band	
		<i>current</i>	<i>future</i>
PMR VHF Low	68 - 7	PMR	
PMR VHF Low	75.2 - 8	PMR	
FM Radio	87.5 - 1	FM Radio	
PMR VHF Mid	138 - 1	PMR	
PMR VHF High	156.8 - 1	PMR	
T-DAB	174 - 2	T-DAB	DVB-T
TETRA	390 - 4	TETRA	
PMR UHF High	450 - 4	PMR	
UHF TV	470 - 6	DVB-T	
800 MHz	791 - 8	LTE FDD	
900 MHz	925 - 9	GSM, UMTS	LTE FDD
1800 MHz	1805 - 1	GSM, LTE FDD	
2.1 GHz	2110 - 2	UMTS FDD	LTE FDD
WIFI 2.4GHz	2400 - 2	WIFI	
3.6 GHz	3410 - 3	BWA, WiMAX, LTE TDD,	
WIFI 5 GHz Indoor	5150 - 5	WIFI	
WIFI 5 GHz Outdoor	5470 - 5	WIFI	
BWA (Licence-exempt)	5725 - 5	BWA, WiMAX	
BWA 10 GHz	10154 - 1	BWA, WiMAX	
Noise	To be measured in bands where present	Noise	

Table 3 - Frequency bands to be measured at all sites

38. As a result of the extraordinary situation presented by COVID-19 and the Government restrictions put in place, electronic communications networks have experienced increased traffic in relation to both voice and data services (Temporary Situation). To assist networks during the Temporary Situation, ComReg made spectrum available for new rights of use in the 700 MHz and 2.6 GHz bands and made rights of use available to the existing mobile network operators (MNO's) in the 2.1 GHz on a liberalised basis⁸. Temporary ECS licences have been issued to the Three MNO's and these expire on 7 October 2020⁹.

39. Noting that the Temporary Situation is likely to continue for some time yet, ComReg proposed in Document 20/68R to establish a new framework that would allow for further Temporary ECS licences to be issued for up to another 6¹⁰ months where licences would expire early April 2021. Therefore, in addition to Table 3 above, frequency selective measurements will have to be conducted in the bands as contained in Table 4 below while any Temporary ECS Licences are in place.

Band Name	Frequency Range (MHz)	Likely Emission/Signal Types in Band
700 MHz	758 - 788	LTE FDD, 5G NR FDD
2.1 GHz	2110 - 2170	UMTS FDD, LTE FDD
2.6 GHz	2500 - 2686	LTE, 5G NR FDD in: UL: 2500-2570 MHz / DL: 2620-2690 MHz TDD in: 2570-2620 MHz

Table 4 - Bands available for temporary licensing during Covid-19 Pandemic

40. From 2021 onwards, the long term rights of use for the frequency bands, as shown in Table 5, may become available for new services and technologies, including mobile. When long term spectrum rights of use have been issued by ComReg in those bands following a proposed award¹¹, then frequency selective measurements of those bands will have to be conducted in addition to the bands listed in Table 3.

⁸ As set out in Document 20/27

⁹ See Document 20/64

¹⁰ Temporary ECS Licences would be issued for up to 3 months and may be renewed for up to another 3 months.

¹¹ See further ComReg document 19/124:

Band Name	Frequency Range (MHz)	Likely Emission/Signal Types in Band
700 MHz	758 - 788	LTE FDD, 5G NR FDD
2.1 GHz	2110 - 2170	UMTS FDD, LTE FDD
2.3 GHz	2300 - 2400	LTE TDD, 5G NR TDD
2.6 GHz	2500 - 2686	LTE, 5G NR FDD in: UL: 2500-2570 MHz / DL: 2620-2690 MHz TDD in: 2570-2620 MHz

Table 5 - Future additional frequency bands to be measured at all sites

Important Note 1: Measuring Emission/Signal Types

Section 8 specifies frequency selective measurement methods for the principal emission or signal types likely to be encountered in the bands listed in Table 3. If more than one signal type is present in a frequency band, it may be necessary to perform separate scans of the band for each signal type, as each may require different measurement parameters to be used on the spectrum analyser.

For example, GSM and UMTS transmissions mixed throughout the 900 MHz (925 – 960 MHz) will have to be measured in separate scans as each requires different analyser settings for parameters such as detector and resolution bandwidth.

Important Note 2: Occurrence of Emission/Signal Types within Frequency Bands

It may be that emissions or signals other than those indicated in Table 3, Table 4 and Table 5 occur in the bands listed, i.e. in the case of:

- (a) liberalised bands¹², where use is permitted on a technology neutral basis;
- (b) licence-exempt bands¹³, where multiple technologies can co-exist; or

<https://www.comreg.ie/publication-download/proposed-multi-band-spectrum-award-response-to-consultation-and-draft-decision-the-700-mhz-duplex-2-1-ghz-2-3-ghz-and-2-6-ghz-bands>

¹² E.g. the 800 MHz, 900 MHz and 1800 MHz and 3.6 GHz bands. Other bands may be made available on a liberalised basis in the coming years.

¹³ WIFI 2.4GHz, 3.6 GHz, WIFI 5 GHz Indoor, WIFI 5 GHz Outdoor and BWA (Licence-exempt)

(c) bands which are repurposed at some point to allow use by a new technology.

For example, it might be possible to encounter signal types other than GSM or UMTS in the 900 MHz band. Where they occur, these other signal types will have to be measured separately using the relevant methods outlined in Section 8.

Important Note 3: Sub-bands

In practice when conducting frequency selective measurements with a spectrum analyser, it may be necessary to divide the bands specified in *table 1* into sub-bands, as the limited resolution of the spectrum analyser may result in narrowband signals being lost in the band scan. As such, the bands to be measured must be split into sub-bands if the following condition is not fulfilled by the analyser:

$$\text{Span} / \text{RBW} < \text{number of horizontal trace pixels on analyser display}^{14}$$

Important Note 4: Measurement Duration

The ICNIRP Guidelines specify Reference Levels in terms of unperturbed RMS values. For comparison with the Reference Levels, measurements are to be averaged over several minutes¹⁵.

The ICNIRP 2020 guidelines indicate that these averaging times are not necessarily the same as the measurement times needed to estimate field strengths or other exposure quantities, and that actual measurement times used to provide an appropriate estimate of exposure quantities may be shorter than the intervals specified in the guidelines. The measured RMS value of a signal transmitted at constant power will be indicative once the value stabilises on the spectrum analyser display. Other signal types may not be carrying a full data traffic load or may not be operating at their maximum duty cycle at the time of measurement. In such cases, it may only be possible to calculate an RMS level on the basis of measuring a constant stable signal element such as a beacon signal and extrapolating to an RMS value indicative of transmission at the maximum traffic load or signal duty cycle by applying a correction factor to the measurement.

¹⁴ It should be noted that the number of horizontal pixels used for tracing on the display may differ from the number of horizontal display pixels quoted in the documentation for a spectrum analyser, which could also include horizontal pixels dedicated to other purposes on the display, such as displaying measurement parameters or soft keys. In cases where this is not clear, it is recommended to seek clarification from the manufacturer.

¹⁵ E.g. six minutes for local exposure and thirty minutes for whole body exposure under the ICNIRP 2020 guidelines.

In any case most measurements involve use of max hold on the spectrum analyser. As such, the analyser is not calculating an RMS level for the signal over several minutes, but rather recording the highest level measured over all sweeps undertaken.

Typically, a sufficient number of sweeps must be conducted to display stable levels on the spectrum analyser. For intermittent signals which occur in very short bursts (like PMR) it is more appropriate to sweep for a longer duration (six minutes) in order to capture as many of those signals as possible that are detectable at the measurement point. Required measurement durations or numbers of sweeps are specified by signal type in Section 8.

Important Note 5 - Emissions from Distant Transmitters

It is important to make an accurate assessment of the overall electromagnetic field present at the point of highest emissions near the designated transmitter site in order to assess simultaneous exposure to multiple frequency fields (as per the ICNIRP Guidelines).

Therefore, it is necessary to consider the main field strength contributions of emissions from the designated transmitter site and also secondary contributions from distant transmitters (e.g. adjacent cell GSM base stations, TV transmitters serving the area etc.). To that end, it is necessary to measure bands in which the transmitters at the designated site emit no signals, as signals in those bands from distant transmitters may be apparent at the measurement point. It is important to measure and record those emissions and document them in the site survey report in order to factor them in to the calculation of the Total Exposure Quotients.

5.3 Measurement Procedure

Equipment pre-Check

41. All measurement equipment, such as field strength meters, field probes, spectrum analysers and antennas used must be within calibration (according to the manufacturer's recommendations) and must have been calibrated to traceable standards. RF cables, waveguides and connectors should be individually marked and checked prior to use for mechanical damage and checked regularly for insertion and return loss characteristics. Any changes in antenna factors and cable loss should be programmed into the measurement receiver.
42. It is the responsibility of the survey team to confirm that the calibration factors are correct and updated as necessary prior to each task. A record in the survey notebook should show that the check/update has been made. A check should be made to verify that the correct cable and antenna parameters are loaded and activated in the receiver.

Measurement with Isotropic Antennas

43. When using isotropic antennas, the following measurement procedure must be followed in respect of each measurement band:
 - (1) Mount the antenna on a non-conductive stand (e.g. a tripod) at the measurement point at a height of 1.5 m above the ground or floor.
 - (2) Program the spectrum analyser with the appropriate settings (RBW, VBW, Detector, Sweep Time) for the type of signal or emission to be measured as per Section 8 and implement any additional or alternative procedures outlined in Section 8.
 - (3) Scan the band for emissions. If no emissions whatsoever have been detected in the band, do not proceed with the full measurement recording. Instead save a brief scan of the band. The scan should be included in the subsequent report, in order to document the absence of any signal in the band from the designated transmitter site.
 - (4) Set the spectrum analyser to record measurements over the specified duration and retreat from the antenna.

Measurement with Directional Antennas

44. In instances where directional antennas (horn, dish, log-periodic etc.) are used, it is still important to account for any significant emissions from distant transmitters in addition to those from the nearby designated transmitter site. In such cases, the following measurement procedure must be followed for each frequency band to be measured:

- (1) Mount the antenna on a non-conductive stand (e.g. a tripod) at the *measurement point* at a height of 1.5 m above the ground or floor.
- (2) Program the spectrum analyser with the appropriate settings (RBW, VBW, Detector, Sweep Time) for the type of signal or emission to be measured as per Section 8 and implement any additional or alternative procedures outlined in Section 8.

Measure emissions from the designated transmitter site

- (3) Orient the antenna in the direction of the transmitter.
- (4) Separate measurements must be performed with the antenna oriented in each orthogonal direction to obtain the differently polarised components of the field. The total field may be calculated as:

$$E_{total} = \sqrt{E_x^2 + E_y^2 + E_z^2} \quad \text{or} \quad H_{total} = \sqrt{H_x^2 + H_y^2 + H_z^2}$$

- (5) On each orthogonal direction/polarisation, vary the tilt of the antenna until a maximum signal level has been detected.
- (6) For each orthogonal direction/polarisation, with the upward tilt corresponding to the maximum signal level, set the spectrum analyser to record measurements over the specified duration and retreat from the antenna.
- (7) If no emissions have been detected from the designated transmitter site, do not proceed with the full measurement recording. Instead save a brief scan of the band. The scan should be included in the subsequent report, in order to document the absence of any emissions in the band from the designated transmitter.

Measure Emissions from distant transmitters

- (8) It is also necessary to determine if emissions in the band from distant transmitters are present at the location.

- (9) Separate measurements must be performed with the antenna oriented in each orthogonal direction to obtain the differently polarised components of the field. The total field may be calculated as:

$$E_{total} = \sqrt{E_x^2 + E_y^2 + E_z^2} \quad \text{or} \quad H_{total} = \sqrt{H_x^2 + H_y^2 + H_z^2}$$

- (10) On each orthogonal direction/polarisation, rotate the antenna 360° horizontally while varying the tilt up and down. As the trace mode on the spectrum analyser will have been set to 'Max Hold', or, in some instances, 'Min Hold', as per Section 8, rather than to 'Clear/Write', levels will be recorded for each emission encountered during this rotation.
- (11) For each orthogonal direction/polarisation, set the spectrum analyser to record measurements over the specified duration and retreat from the antenna.
- (12) If no emissions have been detected from distant transmitters, do not proceed with the full measurement recording. Instead save a brief scan of the band. The scan should be included in the subsequent report, in order to document the absence of any emissions in the band from distant transmitters.

6 Measurement Analysis

45. Once the survey has been completed and all measurements have been recorded, the measurements must be analysed in order to assess compliance of the emissions from the site with the reference levels.

6.1 Broadband Measurements

46. The purpose of the broadband measurements is to get an overview of the intensity of the electromagnetic field present at the point of measurement. The average and maximum levels recorded and are to be compared to the lowest relevant reference level¹⁶.

47. If a broadband measurement is higher than the lowest relevant reference level, it does not necessarily follow that the reference levels have been exceeded, as the reference levels are frequency dependent. Analysis of the frequency selective measurements is necessary to assess compliance with the reference levels.

6.2 Frequency Selective Measurements

48. Analysis of the frequency selective measurements should proceed in four stages as follows:

Stage 1: Selection of Measurements for Analysis

For each frequency band for which frequency selective measurements were conducted, all emissions with field strengths greater than *the threshold level*¹⁷ must be included in the analysis. If no emission exceeds the threshold level within a frequency band the two highest emissions must be included. However, it is permissible to include all detected emissions in the analysis.

Stage 2: Calculation of Adjusted Levels

Where applicable an adjusted level is to be calculated from the measured level for any or all of the following reasons:

¹⁶ E.g. 27.7 V/m for whole body exposure, as set out in Table 5 of the ICNIRP 2020 Guidelines.

¹⁷ The threshold level is 40 dB below the relevant Reference Level for a particular frequency. For E-Field measurements, this corresponds to a factor of 100 times below the Reference Level.

- (a) To compensate for when emission bandwidth exceeds spectrum analyser RBW (RBW Correction Factor)¹⁸
- (b) To extrapolate to a Maximum Traffic Level or Duty Cycle (e.g. for GSM, TETRA & UMTS)¹⁹
- (c) To apply a Correction Factor for emissions with complex signal structures (e.g. PAL TV)²⁰

Stage 3: Assessment of ICNIRP Compliance of Individual Emissions

The level for each emission, which has been adjusted where applicable, is compared to the reference level which applies at the particular frequency of the emission in order to determine their compliance with the reference levels.

Stage 4: Assessment of ICNIRP Compliance of Cumulative Emissions

The levels (adjusted where applicable) for all the emissions are used to calculate two Total Exposure Quotients²¹ in order to assess simultaneous exposure to multiple frequency fields (i.e. emissions on different frequencies from multiple transmitters located at the designated site and also at distant sites). The calculated values of the quotients must be < 1 in order for the aggregate of NIR emissions to satisfy the criteria of the ICNIRP Guidelines.

¹⁸ See Appendix 3

¹⁹ See Section 8

²⁰ See Section 8

²¹ See Appendix 2

7 Reporting Measurement Results

49. The measurement results are documented in the Site Survey Report²² which must include the following:

- Address of designated transmitter site surveyed;
- Date of survey;
- Measurement point address and coordinates (latitude / longitude);
- Atmospheric temperature in °C at measurement point;
- Photos of transmitter site and measurement equipment (as set up at the measurement point);
- Map of the area around the transmitter site indicating the measurement location;
- Outline of the conduct of the survey.

50. In respect of broadband measurements, the report must fully document all measurements made in each band:

- Levels measured;
- Field strength meter used: Manufacturer, Model, Serial no., Calibration Date;
- Probe used: Manufacturer, Model, Serial no., Calibration Date, Frequency Range.

51. The report must fully document all frequency selective measurements made in each band as follows:

- Frequency band measured;
- Spectrum analyser trace;
- Tabulation (example below) of measurements in each band including:

²² The format of the report is specified by ComReg and may be revised from time to time.

- Centre frequency and level for each emission measured
 - Calculations of adjusted levels where applicable
 - Comparison of measured and adjusted levels to the relevant reference levels
- Spectrum analysers and antennas used: Manufacturer, Model, Serial no., Calibration Date, Frequency Range;
 - Spectrum analyser settings: Hold, RBW, VBW, Detector, Sweep time;
 - Measurement Uncertainty²³.

Frequency		Measured E-Field		Adjusted E-Field			
UMTS Channel (MHz)	ICNIRP Limit (V/m)	Level (V/m)	Times below limit	RBW Correction Factor	Max Traffic Extrapolation Factor	Adjusted Level (V/m)	Times below limit
2113.600	61.00	0.63090	96.7	2.0449	3.1623	4.07984	14.95
2128.600	61.00	0.20280	300.8	2.0449	3.1623	1.31145	46.51

Table 6 - Example of table of frequency selective measurements in UMTS band

52. The report must contain a full analysis of the frequency selective measurements including the following:

- Tabulation of all frequency selective measurement results from all bands;
- Assessment of ICNIRP compliance of individual emissions;
- Calculation of total exposure quotients; and
- Overall conclusions.

²³ For each band measured, the measurement uncertainty should be stated. Calculations of the uncertainty should be included in the report. Measurement uncertainty is to be estimated in accordance with either the method outlined in Annex 5 - § 5 of ECC/REC/(02)04 or the method outlined in EN 50492:2008/A1:2014 pp. 19 – 22.

8 Frequency Selective Measurements - Specific Procedures by Signal / Emission Type

8.1 PMR

53. This sub-section outlines a method for measuring emissions from professional/private mobile radio (PMR) base stations. PMR networks are generally used within organisations to serve closed user groups and can consist of a number of handheld radios (walkie-talkies) or vehicle mounted mobile terminals, often connected to one or more base stations. Popular applications include taxi and courier coordination, security and stewarding at events.

54. PMR systems transmit in VHF and UHF bands. Traditionally PMR systems have used analogue FM modulation and systems using digital modulation schemes have begun to be deployed in recent years. 12.5 kHz signal bandwidths are common, with some older systems using up to 25 kHz bandwidths for transmission.

55. The measurement approach for measuring PMR emissions in the frequency domain, including parameters to be used on the spectrum analyser, is outlined in Table 7 below.

Trace Mode	Max Hold
Detector	RMS
RBW	30 kHz
VBW	3 x RBW
Sweep Time	100 ms
Measurement Duration	6 minutes PMR systems tend to transmit intermittently or in very short bursts (often a few seconds). As such the measurement should last a full 6 minutes on Max Hold in order to capture as many PMR signals as possible that are detectable at the measurement point.
Measurement Mode	Frequency Domain

Table 7 - PMR frequency domain measurement method

8.2 FM Radio for Broadcasting

56. This sub-section outlines a method for measuring emissions from Broadcast FM radio transmitters. FM radio transmissions occur in the band 87.5 – 108 MHz, relayed from transmitters located at number of mostly high sites around the country.

57. The transmitted signal consists of a main audio carrier using analogue FM modulation as well as an optional very narrowband (57 kHz) digital subcarrier for Radio Data System (RDS) signals. The RDS subcarrier is BPSK-modulated and allows low bandwidth digital information such as station name to be embedded in an FM radio broadcast. In FM stereo signals the bandwidth can reach up to 256 kHz or as far as 269 kHz if RDS is in use. The FM signal is transmitted at more or less constant power.

58. The approach for measuring FM radio emissions in the frequency domain, including parameters to be used on the spectrum analyser, is outlined in Table 8 below.

Trace Mode	Max Hold
Detector	RMS
RBW	<ul style="list-style-type: none"> • 300 kHz or <ul style="list-style-type: none"> • Sufficient to cover the maximum possible signal bandwidth of 269 kHz.
VBW	3 x RBW
Sweep Time	100 ms
Measurement Duration	A sufficient number of sweeps to achieve stable levels for the FM Radio signals present in the band.
Measurement Mode	Frequency Domain

Table 8 - Broadcast FM Radio frequency domain measurement method

8.3 T-DAB

59. This sub-section outlines a method for measuring emissions from Terrestrial Digital Audio Broadcasting (T-DAB) transmitters. T-DAB refers to the technology used for digital broadcast radio transmission in Ireland. T-DAB allows several radio stations to be relayed on a single multiplex. Transmissions occur in the 174 – 230 MHz band, relayed from transmitters at several high sites around the country.

60. A T-DAB multiplex is transmitted on a single centre frequency by means of Orthogonal frequency-division multiplexing (OFDM). The signal consists of 1536 subcarriers across its full bandwidth (1.536 MHz), with each subcarrier individually modulated using DQPSK. The signal is transmitted at more or less constant power, except for periodic decreases for synchronisation purposes.

61. The measurement approach for measuring T-DAB emissions in the frequency domain, including parameters to be used on the spectrum analyser, is outlined in Table 9 below.

Trace Mode	Max Hold
Detector	RMS
RBW	<ul style="list-style-type: none"> • Sufficient to cover signal bandwidth of 1.536 MHz (e.g. 1.6 MHz or 2 MHz) or <ul style="list-style-type: none"> • Narrower than signal bandwidth if RBW correction factor is applied as per Appendix 3. (For analysers with available RBWs narrower than signal bandwidth)
VBW	3 x RBW
Sweep Time	100 ms
Measurement Duration	A sufficient number of sweeps to achieve stable levels for the T-DAB signals present in the band.
Measurement Mode	Frequency Domain

Table 9 - T-DAB frequency domain measurement method

8.4 TETRA

Overview of TETRA signals

62. A TETRA downlink consists of one or more RF carriers. The access scheme is TDMA, with carriers bearing frames of approximately 56.67 ms duration. Each frame carries four time slots with each slot occupied by an independent channel, such as the Main Control Channel (MCCH), Traffic Channels (TCH) and Packet Data Channel (PDCH) etc. On one of the carriers, known as the main carrier, the first slot of each frame is dedicated to the MCCH. The MCCH is principal common control channel transmitted by the network to control the mobile stations in a TETRA cell and is transmitted at constant power independent of traffic. Other carriers become available to provide additional voice and data capacity as required. Figure 1 illustrates how the channels are multiplexed within frames.

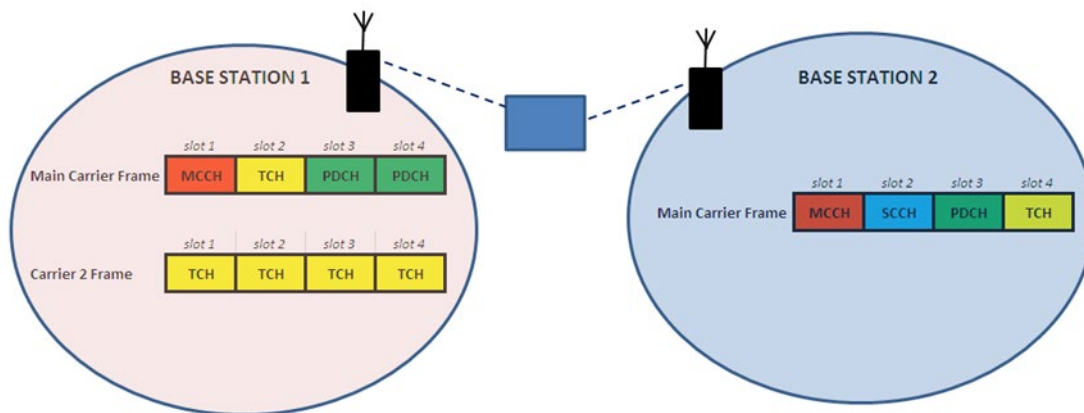

Figure 1- Example channel configuration on TETRA frames

63. The carrier bandwidth is 25 kHz with DQPSK modulation. Release 2 of the TETRA standard allows for QAM modulation for higher data rates, in which case the carrier bandwidth can be 25 kHz, 50 kHz, 100 kHz or 150 kHz.

TETRA measurement method

64. TETRA base stations produce emissions which vary in accordance with the number of users. As such, a direct measurement of downlink emissions at a point in time may not necessarily be indicative of emission levels resulting from maximum traffic throughput. EN 50492:2008/A1:2014 (pp. 52-53) recommends measuring the emissions of the main carrier bearing the MCCH of a TETRA downlink and then extrapolating to a level for maximum power and traffic based on the total number of carriers in use, on the basis that the MCCH is transmitted at constant power regardless of traffic.
65. The basic approach involves measuring each main carrier for each TETRA downlink detectable at the measurement point and extrapolating to what the emission level would be if the downlinks were carrying maximum traffic at maximum power. Several main carriers may be detectable, originating from the different sectors of each TETRA base station located at the designated transmitter site or from other sites nearby.
66. As per EN 50492:2008/A1:2014, the maximum emission level (for maximum traffic and power) attributable to each TETRA downlink detected is then extrapolated from the E-field measurement of each main carrier, based on the number of transmitters associated with each downlink i.e. number of carriers.
67. The measurement approach, including parameters to be used on the spectrum analyser, is summarised in Table 10 and outlined in further detail below.

Trace Mode	Max Hold
Detector	Peak
RBW	Depends on the carrier bandwidth: 25 kHz, 50 kHz, 100 kHz or 150 kHz. Ideally the RBW should match the signal bandwidth. Otherwise the RBW should be the next RBW available on the spectrum analyser greater than the carrier bandwidth, e.g. 30 kHz RBW for a 25 kHz carrier.
VBW	≥RBW
Sweep Time	100 ms
Measurement Duration	A sufficient number of sweeps to achieve stable levels for the TETRA signals present in the band.
Measurement Mode	Frequency Domain
Extrapolation for Max Traffic Load	<p>Calculate the level for maximum traffic E_{MAX} by applying a correction factor to the measured level E_{MCCH} for each main carrier bearing an MCCH:</p> $E_{MAX} = E_{MCCH} \times \sqrt{n_{TRX}} \quad (V/m \text{ Calculation})$ <p>Where</p> <p>n_{TRX} = the number of carriers on a TETRA downlink (including the main carrier).</p> <p>n_{TRX} includes the main carrier plus the number of other carriers associated with it.</p> <p>n_{TRX} = 3 for TETRA (Emergency) in 390 – 395 MHz</p> <p>n_{TRX} = 2 for TETRA (Civil) in 395 – 400 MHz</p>

Table 10 - TETRA measurement method

68. When conducting measurements of TETRA downlinks, the following procedures must be followed with reference to Table 10.

Frequency Selective Measurement Procedure

69. Before commencing frequency selective measurements in the TETRA bands, firstly identify and note down the frequencies of all the main carriers present in the band. It is recommended that the spectrum analyser trace be set to Min Hold. This will help to resolve the constant power MCCHs on the main carrier, while other variable power carriers will be screened out.

70. With the spectrum analyser programmed with the parameters as shown in Table 10, continue according to the standard procedure for Measurement with Isotropic Antennas.

Measurement Analysis Procedure

71. Identify the measured levels for the main carriers from the frequency selective scan. The main carriers can be identified on the basis of the frequencies noted down earlier.

72. Estimate the level for maximum traffic EMAX associated with each main carrier as per Table 10.

Reporting Measurement Results

73. The following information must be documented in the site survey report in respect of each downlink measured:

- Main MCCH Carrier frequency in MHz;
- Measured Level;
- Number of carriers;
- Adjusted Level. i.e. Estimated level for maximum traffic and power.

74. The adjusted level is compared to the relevant Reference Level and is used in the calculation of the Total Exposure Quotients.

8.5 DVB-T

75. This sub-section outlines a method for measuring emissions from Terrestrial Digital Video Broadcasting (DVB-T) transmitters. DVB-T refers to the technology used for digital television transmission in Ireland. DVB-T allows several television channels to be relayed on a single multiplex. Currently transmissions occur in the 470 - 790 MHz band, relayed from transmitters located at a number of mostly high sites around the country. The national Multichannel Microwave Distribution System (MMDS) network also transmits using DVB-T in the band 2500 – 2686 MHz. It is possible that the 174 – 230 MHz band may also be used in the future.

76. A DVB-T multiplex is transmitted on a single centre frequency by means of Orthogonal Frequency Division Multiplexing (OFDM). Payload is transported on 6817 subcarriers across the full signal bandwidth, with each subcarrier individually modulated using either QPSK, 16QAM or 64QAM. The signal bandwidth can be either 7.61 MHz (in the 470 – 790 MHz band) or 6.66 MHz (in the 174 – 230 MHz band). The signal is transmitted at more or less constant power.

77. The measurement approach for measuring DVB-T emissions in the frequency domain, including parameters to be used on the spectrum analyser, is outlined in Table 11 below.

Trace Mode	Max Hold
Detector	RMS
RBW	<ul style="list-style-type: none"> • Sufficient to cover signal bandwidth (e.g. 8 MHz for 7.61 MHz wide signals) or • Narrower than signal bandwidth if RBW correction factor is applied as per Appendix 3. (For analysers with available RBWs narrower than signal bandwidth)
VBW	3 x RBW
Sweep Time	100 ms
Measurement Duration	A sufficient number of sweeps to achieve stable levels for the DVB-T signals present in the band.
Measurement Mode	Frequency Domain

Table 11 - DVB-T frequency domain measurement method

8.6 GSM

Overview of GSM signals

78. A GSM downlink consists of several RF carriers, each of which occupies a 200 kHz channel. The access scheme is Time Division Multiple Access (TDMA) combined with frequency hopping. Each carrier bears TDMA frames of duration 4.615ms. Each frame in turn consists of 8 timeslots, each of approximately 577 μs. Logical channels such as Traffic Channels (TCH) for calls and various control channels for system signalling and synchronisation are multiplexed in each timeslot (Figure 2).

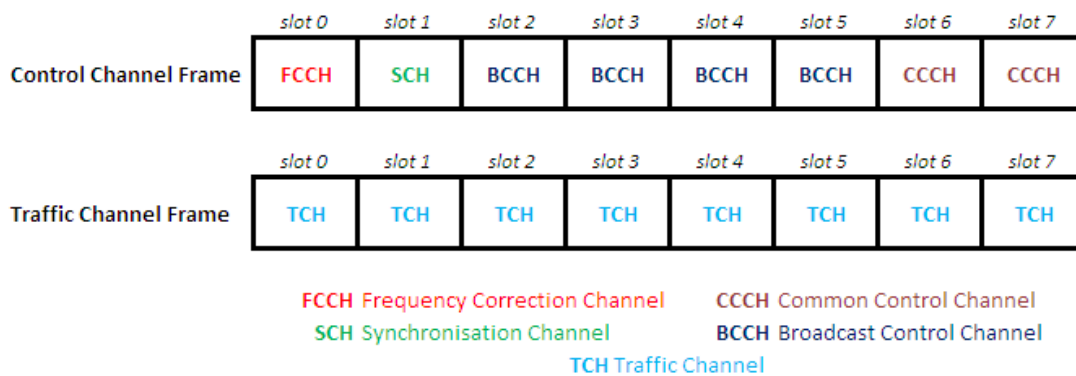

Figure 2 - Example of Multiplexing of GSM logical channels in TDMA frames

79. At each base station there is at least one channel transmitting on constant power within each sector, the Broadcast Control Channel (BCCH). The BCCH acts as a beacon channel to indicate that a GSM base station is active and is used to send information about the network and the base station itself (e.g. network identity, channel lists, neighbouring cells etc) to enable handsets to connect to the network. As a beacon channel, a BCCH is transmitted continuously at full power. The RF carrier used to transmit the BCCH is referred to as the BCCH carrier.

80. Associated with a BCCH carrier are several other TCH carriers used to relay voice and data traffic on the downlink (Figure 3).

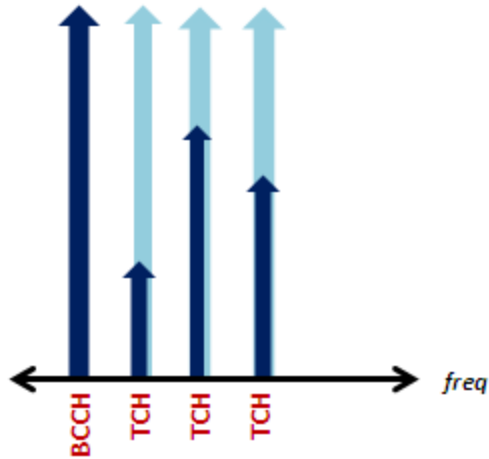

Figure 3 - BCCH carrier and associated TCH carriers from a GSM cell sector

81. In contrast to the power of a BCCH carrier, the transmit power of TCH carriers varies with traffic load and use of transmit power control (compare Figure 4 and Figure 5). Some timeslots in frames may be empty when there are no calls to relay while a TCH in one timeslot, destined for more distant mobiles, may be transmitted at higher power than TCHs in other timeslots, destined for mobiles closer to the base station.

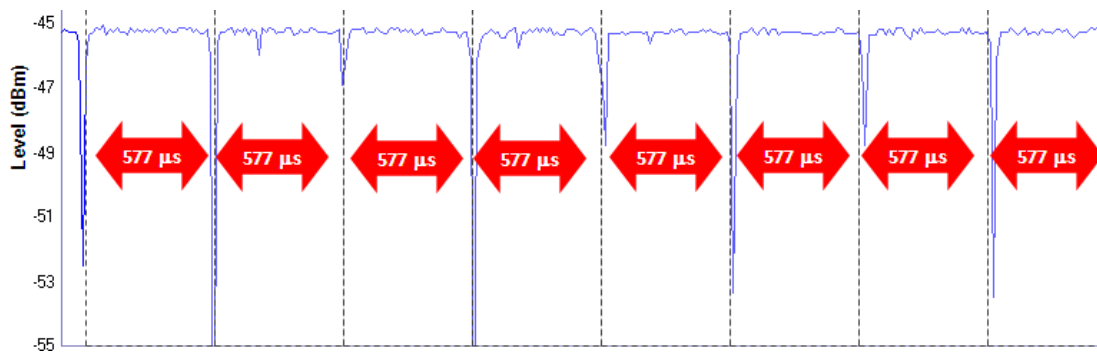

Figure 4 - BCCH carrier in time domain - constant power of BCCH in each 577 μs timeslot

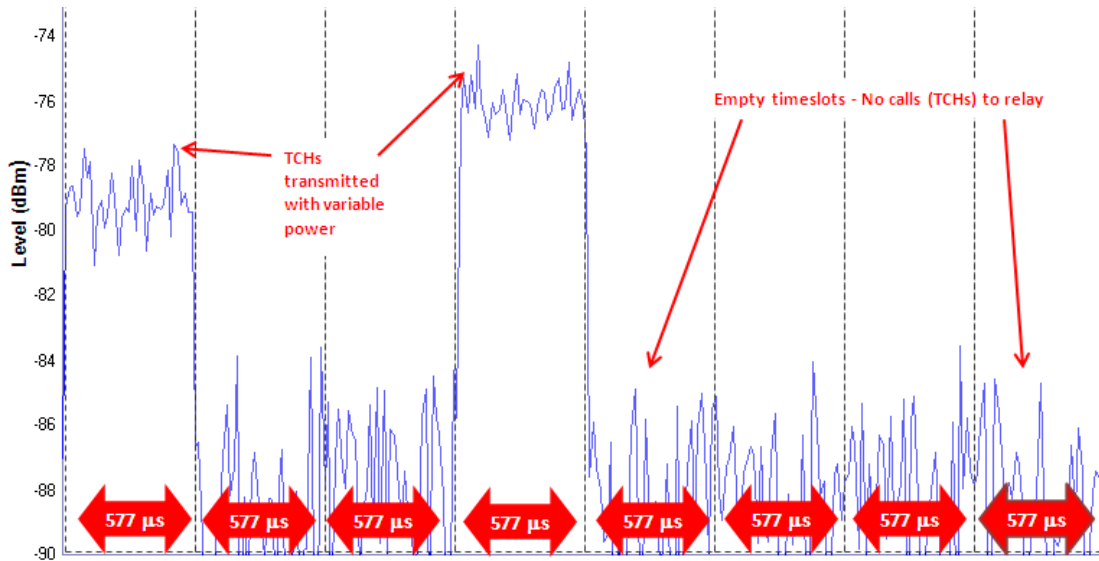

Figure 5 - TCH carrier in time domain - variable power of TCHs in each 577 μs timeslot

82. The GSM standard allows for frequency hopping as a technique to alleviate the effects of multipath fading for TCH channels. There are two types of frequency hopping: base band frequency hopping and synthesised frequency hopping. In base band hopping, each TCH carrier is transmitted on a fixed frequency, while calls and data are periodically switched between TCH carriers e.g. every timeslot. In synthesised frequency hopping, calls and data remain on the same TCH carriers from timeslot to timeslot. Instead, the TCH carriers themselves hop in frequency every timeslot.

GSM measurement method

83. The basic approach involves measuring each BCCH carrier detectable at the measurement point and extrapolating to what the emission level would be if all TCH carriers associated with each BCCH carrier were carrying maximum traffic i.e. transmitted at full power. A number of BCCH carriers may be detectable, originating from the different sectors of each GSM base station located at the designated transmitter site or from other sites nearby. As per EN 50492:2008/A1:2014 (pp. 18 & 50), the maximum emission level (for maximum traffic) attributable to each GSM downlink detected is then extrapolated from the E-field measurement of each BCCH based on the number of transmitters associated with each downlink i.e. BCCH carrier plus TCH carriers.

84. The measurement approach, including parameters to be used on the spectrum analyser, is summarised in Table 12 and outlined in further detail below.

Trace Mode	Max Hold
Detector	Peak
RBW	200 or 300 kHz
VBW	≥ RBW
Sweep Time	100 ms
Measurement Duration	A sufficient number of sweeps to display stable signal levels on the analyser screen
Measurement Mode	Frequency Domain
Extrapolation for Max Traffic Load	<p>Calculate the level for maximum traffic E_{MAX} by applying a correction factor to the measured level E_{BCCH} for each BCCH:</p> $E_{MAX} = E_{BCCH} \times \sqrt{n_{TRX}} \quad (V/m \text{ Calculation})$ <p>Where</p> <p>n_{TRX} = the number of carriers on a GSM downlink.</p> <ul style="list-style-type: none"> n_{TRX} includes the BCCH plus the number of TCHs associated with it. If the number of TCHs per BCCH is not known, n_{TRX} is taken as 4.

Table 12 - GSM measurement method

85. When conducting measurements of GSM downlinks, the following procedures must be followed with reference to Table 12:

Frequency Selective Measurement Procedure

86. Before commencing frequency selective measurements in bands used for GSM, using a spectrum analyser, firstly identify and note down the frequencies of all the BCCH carriers present in the band.

87. If a carrier is seen to remain at constant power on one frequency, it is likely that it is a BCCH carrier. In contrast, TCH carriers can be seen to vary in power if base band frequency hopping is used, or to hop about the band adjacent to the BCCH carrier if synthesised hopping is in use. Also, setting the spectrum analyser trace to **Min Hold** will help to resolve the constant power BCCHs, while the variable power TCHs will be screened out.

88. With the spectrum analyser programmed with the parameters as shown in Table 12, continue according to the standard procedure for Measurement with Isotropic Antennas.

Measurement Analysis Procedure

89. Identify the measured levels for the BCCH channels from the frequency selective scan. The BCCH carrier frequencies can be identified on the basis of the frequencies noted down earlier.

90. Estimate the level for maximum traffic E_{MAX} associated with each BCCH carrier as per Table 12.

Reporting Measurement Results

91. The following information must be documented in the site survey report in respect of each GSM downlink measured:

- BCCH carrier frequency in MHz
- Measured Level
- Number of carriers (BCCH + TCHs) for the downlink
- Adjusted Level. i.e. Estimated level for maximum traffic

92. The adjusted level for each BCCH carrier is compared to the relevant Reference Level and is used in the calculation of the Total Exposure Quotients.

8.7 UMTS

Overview of UMTS signals

93. In UMTS (or 3G) networks access to the radio transmission medium is based on Wideband Code Division Multiple Access (WCDMA). WCDMA enables various connections to share the same frequency channel by spreading narrowband data streams spread across RF channels of much greater bandwidth (Figure 6 Table 6 - Example of table of frequency selective measurements in UMTS band). Different users connected to a base station are distinguished by means of unique spreading codes, such that all users can use the same frequency channel at the same time. The data streams for each connection are encoded at the transmission end in such a way that the receiver, knowing the code, can extract the wanted signal from other signals on the same WCDMA channel. Other unwanted signals appear as noise at the receiver.

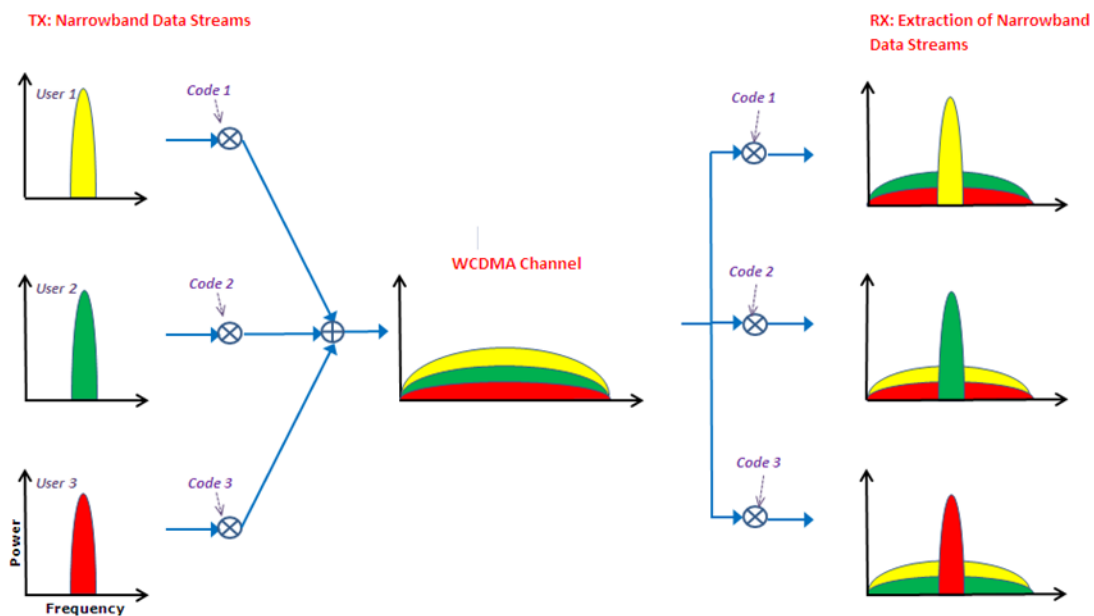

Figure 6 - WCDMA basic principles

94. UMTS systems support duplex communication between base station (node B) and mobile station (UE) via either Frequency Division Duplex (FDD) or Time Division Duplex (TDD) modes. In FDD mode the node B and UEs transmit on separate channels in different frequency bands, while in TDD mode the uplink and downlink transmissions are separated in time and both the node B and the UEs transmit on the same frequency channel in alternating timeslots. In Ireland, UMTS node Bs transmitting in the band 2110 – 2170 MHz operate in FDD mode (with UEs up linking in 1920 – 1980 MHz), while node Bs transmitting in the band 1900 – 1920 MHz use TDD mode. In addition, the 800 MHz, 900 MHz and 1800 MHz Liberalised Use²⁴ frequency bands support UMTS FDD configurations, should the mobile operators choose to implement UMTS in any of those bands.

95. The output power, and therefore the level of emissions, from a node B depends on the traffic volume and number of users connected. The power in a UMTS channel increases as the power from the data streams of additional traffic channel is spread across the channel (Figure 7).

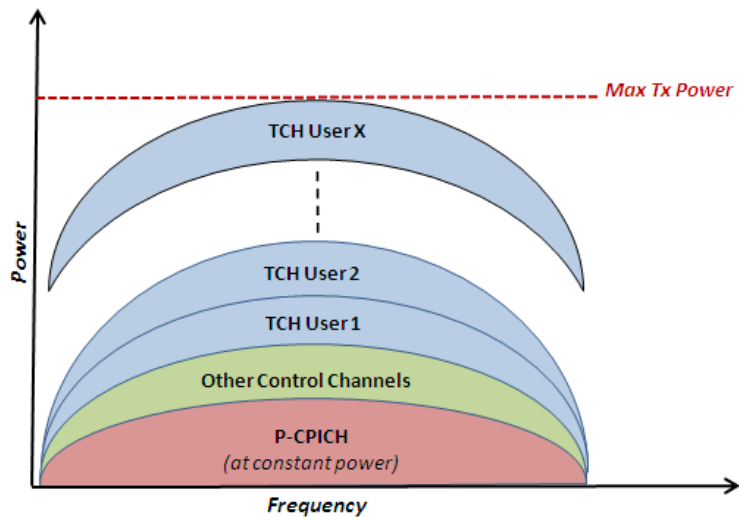

Figure 7 - Tx power variation of UMTS signal with user traffic

²⁴ Liberalised Use Bands:

1

Band	Uplink	Downlink
800 MHz	832 - 862	791 - 821
900 MHz	880 – 915	925 – 960
1800 MHz	1710 – 1785	1805 – 1880

96. In addition to traffic channels, a number of control and synchronisation channels are transmitted within a UMTS signal. Of these channels, the Primary Common Pilot Channel (P-CPICH) is of particular interest in the context of NIR emissions measurement, as it is continuously transmitted at constant power in the downlink regardless of whether data traffic is present. The P-CPICH is typically allocated 10% of the maximum power (i.e. power in a full traffic configuration) of a UMTS signal (EN 50492:2008/A1:2014, p. 51). As such, it is suitable for measurement and consequent extrapolation to the emission level resulting from the downlink under maximum traffic conditions.

97. UMTS signals occupy a 5 MHz channel in FDD mode. In TDD mode, two channel bandwidths are possible: 5 MHz for High Chip Rate (HCR) signals and 1.8 MHz for Low Chip Rate (LCR) signals. Channel and corresponding signal bandwidths are shown in Table 13.

Mode	Channel Bandwidth (MHz)	Signal Bandwidth (MHz)
FDD	5	4.6
TDD HCR	5	4.6
TDD LCR	1.6	1.47

Table 13 - UMTS channel and signal bandwidths

UMTS measurement approach

98. The basic approach to measuring UMTS signals involves an assessment of the contribution of the P-CPICH components within each UMTS signal detectable at the measurement point and then extrapolating to what the levels for each signal would be if they were carrying a full traffic load.
99. Several UMTS signals may be apparent in the UMTS downlink bands and also within the Liberalised Use bands. As operators reuse the same frequency channels in every cell and sector in their networks, it may be the case that a signal is the aggregate of separate signals from different sectors on the same node B or from adjacent node Bs. As such, a signal may contain multiple P-CPICHs.
100. This section outlines two methods for measuring UMTS signals: spectral and code selective measurement. Spectral measurement involves measuring each UMTS signal in the frequency domain, using this measurement as an estimate of the power contribution of the one or more P-CPICHs on the channel and then extrapolating to an estimate of the level of each signal when maximum traffic is present. Code selective measurement involves decoding and separate measurement of each P-CPICH on a UMTS channel, using the UMTS P-CPICH demodulation function available on some spectrum analysers. The approach to extrapolating from the P-CPICH contribution in a UMTS signal to a level for maximum traffic condition is as per the recommendations in EN 50492:2008/A1:2014 (p. 51).

UMTS spectral measurement method

101. The measurement approach, including parameters to be used on the spectrum analyser, is summarised in Table 14 and outlined in further detail below.

Analyser Hold/ Trace Mode	Min Hold for FDD downlinks
	Max Hold for TDD downlinks
Detector	RMS
RBW	4.6 or 5 MHz
	for FDD and TDD HCR UMTS signals with a bandwidth of 4.6 MHz
	1.47 or 1.5 MHz
	For TDD LCR UMTS signals with a bandwidth of 1.47 MHz
	If the spectrum analyser does not offer the above RBWs, then a narrower RBW (e.g. 1 MHz) may be used and an RBW correction factor (K _{RBW}) should be applied to the measurement to calculate a level for the full signal bandwidth as per Appendix 3
VBW	≥3 x RBW
Sweep Time	100 ms
Measurement Duration	A sufficient number of sweeps to display stable signal levels on the analyser screen
Measurement Mode	Frequency Domain
Extrapolation for Max Traffic Load	<p>Calculate the level for maximum traffic E_{MAX} by applying a correction factor to the measured level E_{UMTS} for each UMTS signal:</p> $E_{MAX} = E_{UMTS} \times K_{RBW} \times \sqrt{n_{p-cpich}} \quad (V/m \text{ Calculation})$ <p>Where</p> <p style="padding-left: 40px;">K_{RBW} is the RBW correction factor applicable when the signal bandwidth exceeds the RBW.</p> <p style="padding-left: 40px;">n_{p-cpich} = 10</p> <p style="padding-left: 80px;">i.e. the ratio of the Tx power of the P-CPICH to the maximum possible power on a UMTS downlink with full traffic.</p>

Table 14 - UMTS spectrum measurement method

102. When conducting measurements of UMTS downlinks, the following procedures must be followed with reference to Table 14:

UMTS Spectral Measurement Procedure

103. For each frequency band containing UMTS signals, continue according to the standard procedure for Measurement with Isotropic Antennas, except that:
- For bands with UMTS FDD signals, the spectrum analyser should be set to MIN HOLD²⁵.
 - For bands with UMTS TDD signals, the spectrum analyser should be set to MAX HOLD²⁶.

UMTS Spectral Measurement Analysis Procedure

104. For each UMTS band measured, Identify the measured levels for all UMTS channels from the frequency selective scans.
105. If the RBW used to perform the measurements is less than the UMTS signal bandwidth, then apply the appropriate RBW correction factor²⁷ to the measured levels.
106. Estimate the level for maximum traffic EMAX associated with each UMTS signal identified as per Table 14.

²⁵ The signal level measured for each UMTS channel is taken as an estimate of the P-CPICH level if the spectrum analyser does not have a UMTS P-CPICH demodulation option capable of identifying and measuring individual P-CPICHs. The level will tend towards the P-CPICH level with less traffic. The probability of capturing the actual P-CPICH level is increased when the analyser is set to MIN HOLD. The measured value will serve as an estimate of the P-CPICH level.

²⁶ If MIN HOLD is used for measuring TDD, the analyser may miss the P-CPICH from the base station as it will record the levels for timeslots when the base station is idle, and the mobile stations are transmitting. If there are no mobile stations transmitting during the uplink timeslots, no P-CPICH will be recorded at all and the minimum level recorded will be that of the noise floor. Setting the analyser to MAX HOLD will avoid this problem. However, it is likely that the levels recorded may include traffic channels in addition to the P-CPICH. This may lead to overestimation when extrapolating to the level for maximum traffic. Therefore, in cases where levels of emissions from the designated transmitter site are found to exceed the Reference Levels, the emissions should be measured again, and an analyser capable of UMTS P-CPICH demodulation should be employed to yield more accurate results.

²⁷ See Appendix 3.

Reporting Measurement Results

107. The following information must be documented in the site survey report for each UMTS signal measured:

- UMTS Channel in MHz;
- Measured Level (P-CPICH);
- Any correction factors applied to the measured level;
- Adjusted Level .i.e. Estimated level for maximum traffic.

108. The adjusted level is compared to the relevant Reference Level and is used in the calculation of the Total Exposure Quotients.

UMTS code selective measurement method

109. A spectrum analyser is required which has a UMTS P-CPICH demodulation function installed. This allows it to decode each P-CPICH present on a UMTS frequency channel i.e. on a single RF carrier. Thus, it can measure and list separately the levels for each P-CPICH.

UMTS Code Selective Measurement Procedure

110. Firstly, using the spectrum analyser, scan the relevant UMTS frequency bands to identify any UMTS signals present.
111. The next step is to measure the individual levels for any P-CPICHs present in each signal. Thus, for each UMTS signal identified, with the analyser in UMTS P-CPICH demodulation mode:
- (1) Select the UMTS channel centre frequency;
 - (2) Ensure that the spectrum analyser is set to integrate the P-CPICH measurement across the full UMTS channel bandwidth, i.e. 5 MHz for FDD and TDD HCR signals and 1.8 MHz for TDD LCR signals;
 - (3) Measurement is conducted using an isotropic antenna mounted on a non-conductive stand (e.g. a tripod) at the measurement point at a height of 1.5 m above the ground or floor;
 - (4) Set the spectrum analyser to record measurements until they stabilise and retreat from the antenna.

UMTS Code Selective Measurement Analysis Procedure

- (1) For each UMTS carrier measured, sum the levels for the P-CPICHs measured on that carrier frequency for the total P-CPICH level:

$$E_{p-cpich}(freq_0) = \sqrt{\sum_{i=1}^n E_{p-cpich_i}^2}$$

(V/m Calculation)

- (2) Next, for each UMTS carrier, calculate the level for maximum UMTS traffic on the carrier by applying a correction factor to the total P-CPICH level:

$$(3) \quad E_{MAX}(freq_0) = E_{p-cpich}(freq_0) \times \sqrt{n_{p-cpich}} \quad (V/m \text{ Calculation})$$

Where $n_{p-cpich} = 10$

i.e. the ratio of the Tx power of the P-CPICH to the maximum possible power on a UMTS downlink with full traffic.

Reporting Measurement Results

112. The following information must be documented in the site survey report for each UMTS signal measured for each UMTS carrier measured:

- (1) UMTS Channel in MHz;
- (2) Measured Level for each P-CPICH on the carrier;
- (3) Total level for P-CPICHs on the carrier;
- (4) Any correction factors applied to the measured levels;
- (5) Adjusted Level. i.e. Estimated level for maximum traffic.

113. The adjusted level is compared to the relevant Reference Level and is used in the calculation of the Total Exposure Quotients.

8.8 LTE

114. This sub-section describes two methods for measuring LTE signals: code selective and spectral measurement. In order to put the measurement methods into context and clarify how they are based on the characteristics of LTE signals, an overview of the structure of LTE signals is first provided.
115. The spectral method is derived from the measurement procedures for emissions from LTE base stations outlined in Bornkessel (2011). The code selective method is based on some of the recommendations in Bornkessel et al (2012, pp. 62-66). These methods are, in the main, consistent respectively with the time domain and code domain LTE measurement methods described in EN 50492:2008/A1:2014. Both methods involve measuring constantly transmitted components of LTE signals and subsequent extrapolation to an estimate of the average emission level under maximum traffic from the base station.
116. An EPRE ratios correction factor is also described to account for possible differences in transmission power between the resource elements of the different physical channels/signals within an LTE signal in cases where the resource elements of the reference, synchronisation or control channels are boosted in transmission power relative to those of the data traffic channels or other channels. This correction factor can be applied to the extrapolated emission levels for maximum data traffic resulting from code selective measurements to avoid overestimation of the average emission level.

8.8.1 Overview of LTE Signal Structure

OFDMA

117. In the downlink LTE uses Orthogonal Frequency Division Multiple Access (OFDMA) whereby multiple narrowband subcarriers are equally spread every 15 kHz across the full signal bandwidth in the frequency domain. Each subcarrier can be modulated individually with data symbols.

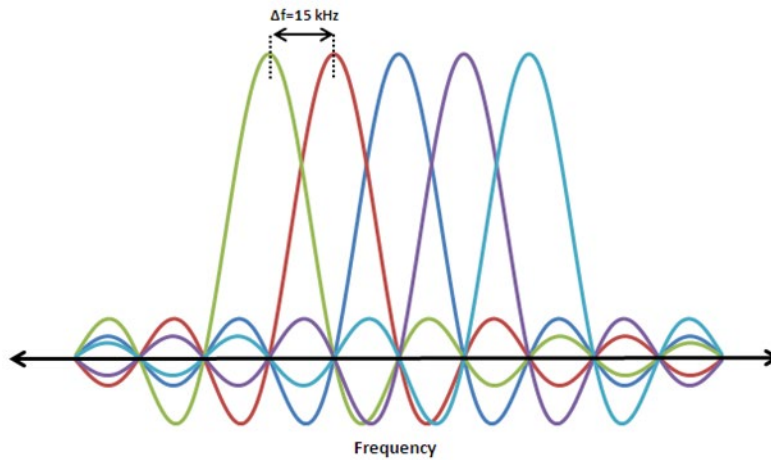

Figure 8 - OFDM subcarrier spacing in LTE

118. The subcarriers are arranged on both sides of the DC subcarrier on the centre frequency, which is not modulated with data.

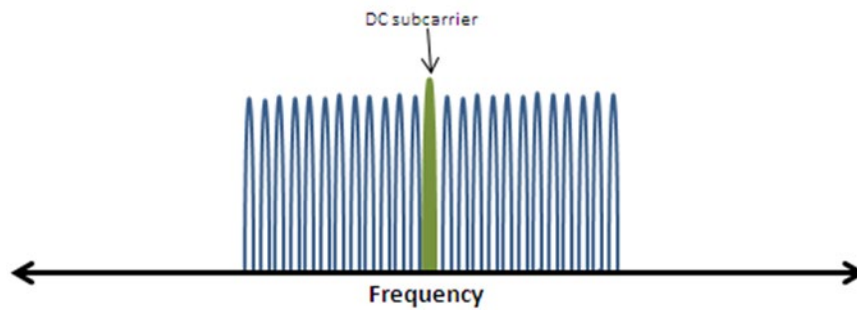

Figure 9 - OFDM multiple subcarriers in LTE downlink

LTE Frame Structures

119. In the time domain LTE transmissions are organised into radio frames 10 ms in length. The LTE standard defines two frame structures: type 1 for FDD and type 2 for TDD. A type 1 frame (Figure 10) is divided into ten subframes, each 1 ms in length. A subframe is further divided into two slots, each 0.5 ms in length. Each slot consists of seven symbols if normal cyclic prefix (CP) is in use or six symbols in the case of extended CP.

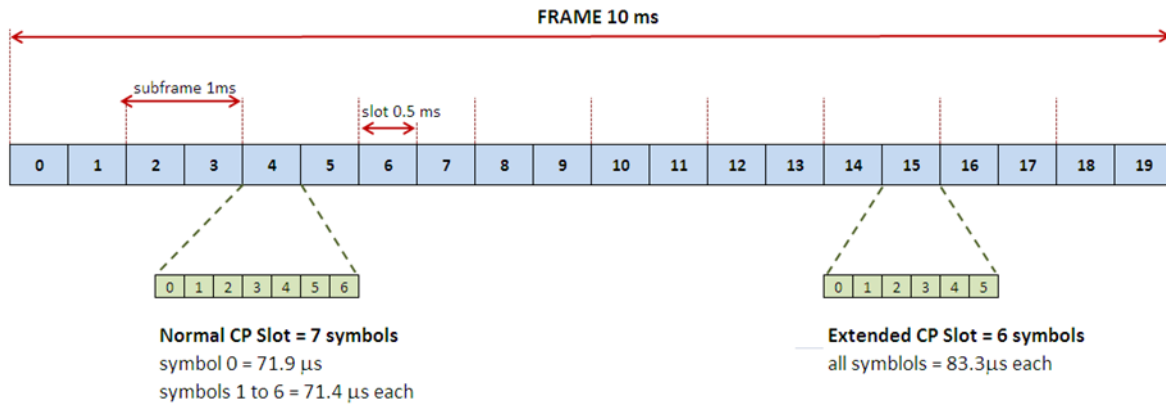

Figure 10 - Type 1 frame structure for FDD

120. Type 2 TDD frames (Figure 11) are made up of two half-frames of 5 ms each, which are further subdivided into five subframes of 1 ms each. Each subframe consists of two 0.5 ms slots, except for special subframes which carry three fields of switch information: downlink pilot timeslot (DwPTS), guard period (GP) and uplink pilot timeslot (UpPTS). Subframes 0 and 5 and DwPTS are reserved for downlink transmission only, with subframe 2 and UpPTS reserved for uplink transmission. The other subframes can be used for either up- or downlink.

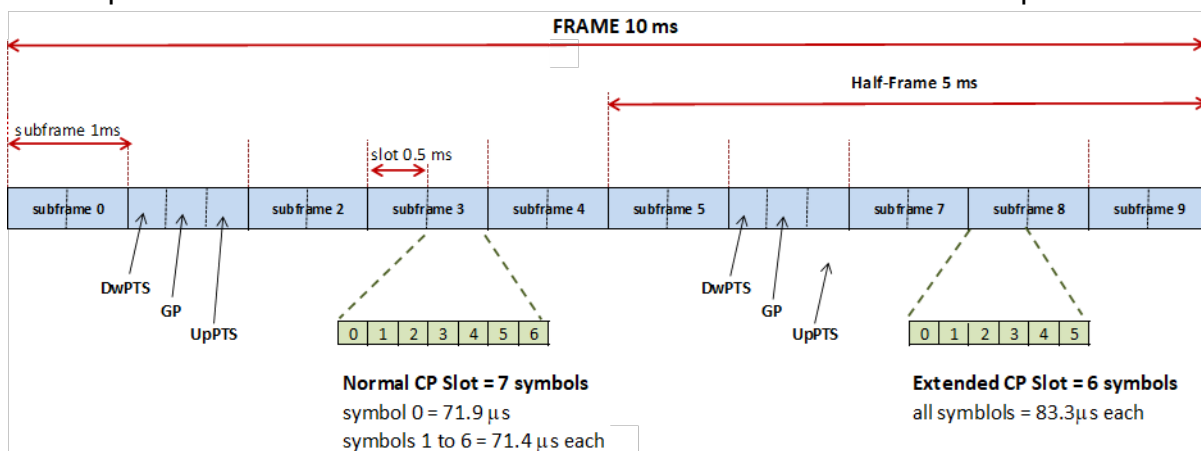

Figure 11 - Type 2 LTE frame structure for TDD

Cyclic Prefix

121. The cyclic prefix acts as a guard interval (Figure 12) to protect against intersymbol interference. It is appended to each symbol and consists of a copy of a portion of the symbol end. In normal CP the cyclic prefix is usually 4.7 μs in length compared to 16.7 μs for extended CP. When the basic symbol length of 66.7 μs is lengthened by the cyclic prefix, the full symbol length becomes 71.4 μs for normal CP and 83.3 μs for extended CP.

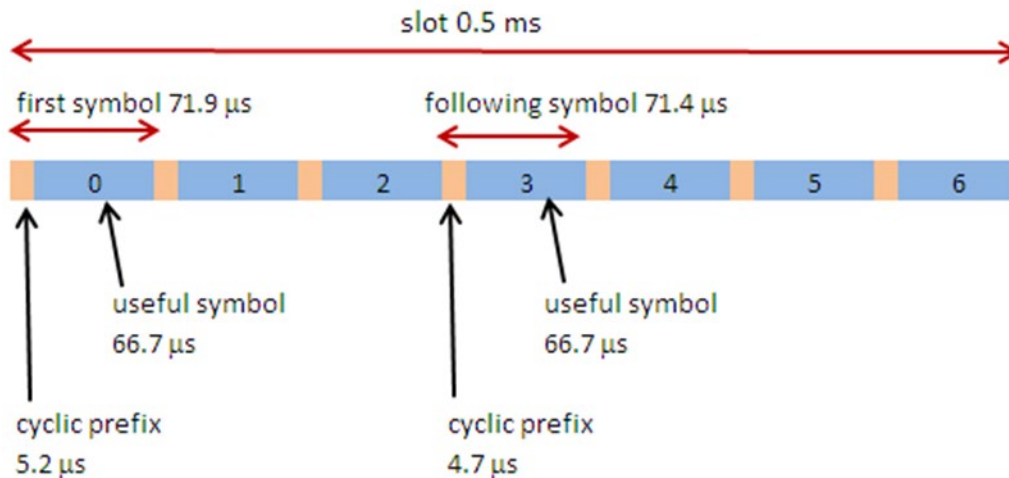

Figure 12 - Use of cyclic prefix as a guard interval (normal CP)

122. Normal CP is intended for use in smaller urban cells with high data rates, while extended CP is designed for larger (e.g. rural) cells which require higher delay spread.
123. LTE offers the facility to relay multimedia broadcast services (MBMS), such as mobile TV, on a single frequency over the network. MBMS data is carried on subcarriers spaced every 7.5 kHz and transported in up to six designated subframes mixed among the regular subframes. Regular data and synchronisation signals etc. are still carried in the regular subframes on 15 kHz subcarriers as normal.
124. In order to cope with larger cell radiuses and propagation delays from multiple cells, an even longer extended cyclic prefix of 33.3 μs is used giving a full symbol length of 100 μs .

LTE Bandwidth

125. A Resource Element (RE) is the smallest defined time-frequency unit for LTE downlink transmission and represents one symbol (over time) on one subcarrier (in frequency). Resource Elements are grouped into Resource Blocks consisting of 12 contiguous 15 kHz carriers (totalling 180 kHz) in the frequency domain and one slot (i.e. 7 symbols for normal CP and 6 symbols for extended CP) in the time domain (Figure 13). A Resource Block is the smallest unit that can be scheduled in the frequency domain. Resource Blocks can be aggregated in the frequency domain in one of six configurations specified in the LTE standard (Table 15). As such, there are six possible channel/signal bandwidths for LTE downlink signals.

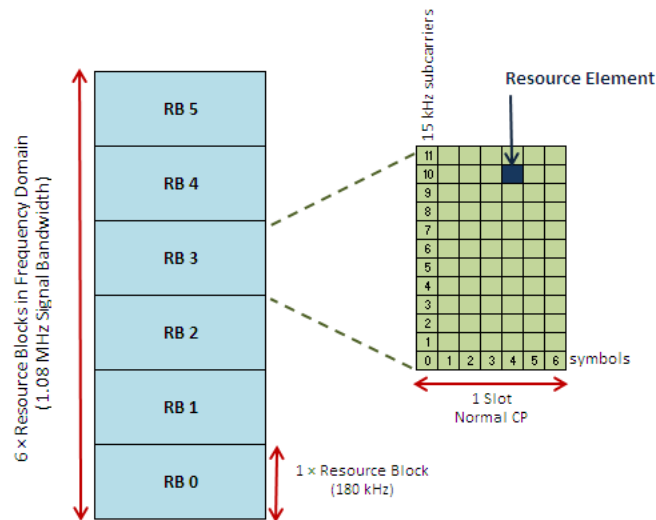

Figure 13 - Resource Elements and Resource Blocks

Channel Bandwidth (MHz)	Signal Bandwidth (MHz)	No. Resource Blocks	No. Subcarriers
1.4	1.08	6	72
3	2.7	15	180
5	4.5	25	300
10	9	50	600
15	13.5	75	900
20	18	100	1200

Table 15 - LTE Bandwidth configurations

LTE Physical Signals and Channels

126. An LTE frame carries physical channels and signals which occupy certain positions in terms of Resource Elements or aggregations of Resource Elements. Channels carry information from higher layers such as data and system information, while signals relate to physical layer functions such as synchronisation. The Resource Grid in Figure 14 represents a snapshot of a single frame on 45 subcarriers either side of the centre DC subcarrier and illustrates how the different channels and signals are allocated within a frame, with each individual square representing a symbol mapped onto a Resource Element, while Table 16 summarises the functions of the signals and channels.

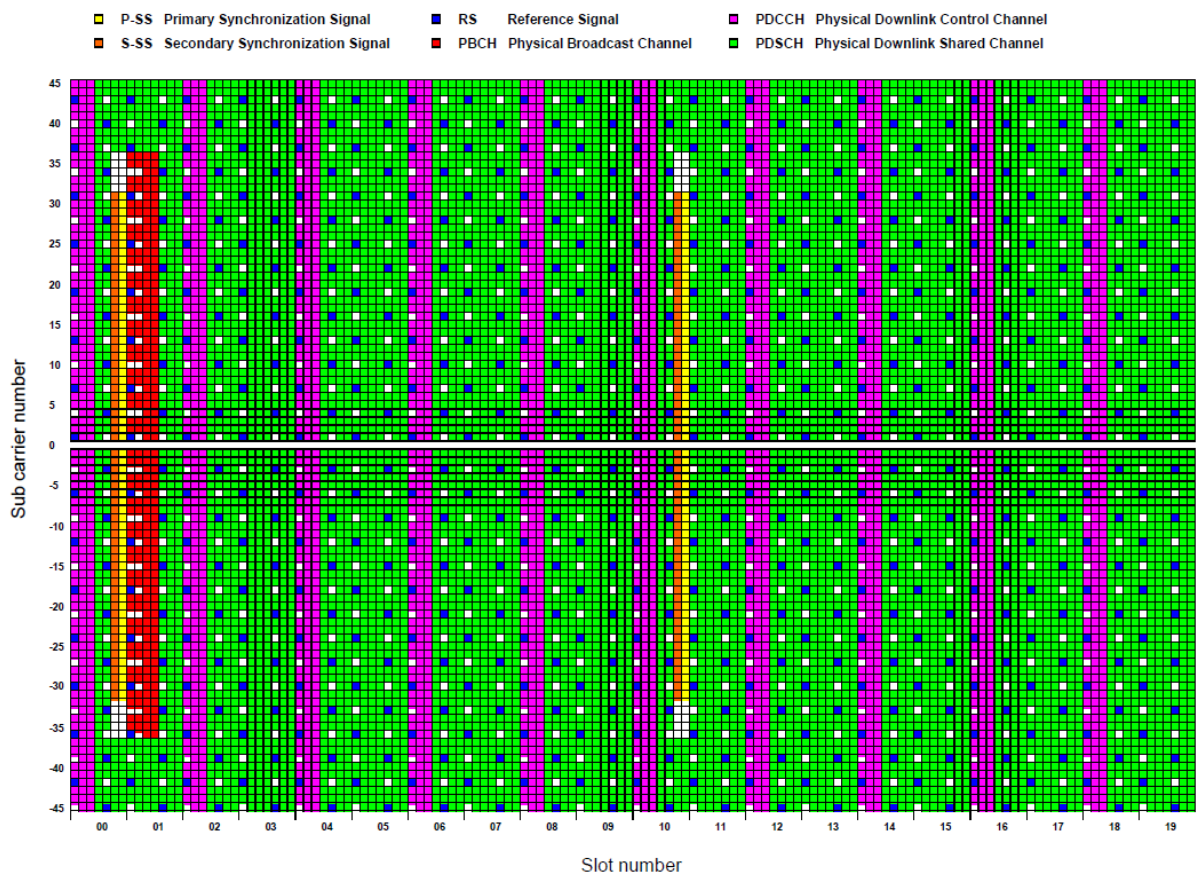

Figure 14 - Resource Grid of Type 1 (FDD) LTE Downlink Frame (x-axis=time, y-axis=frequency)²⁸

²⁸ Source: Bornkessel, 2013, p. 6

LTE DOWNLINK PHYSICAL SIGNALS	
Primary Synchronisation Signal P-SS	Enables subframe, slot and symbol synchronisation by the user equipment and provides cell identity and frequency information during cell search. Transmitted on 62 subcarriers around the centre DC subcarrier. It occurs twice per frame: on the last symbol in slots 0 and 10 in FDD frames, and on the third symbol in subframes 1 and 6 in TDD frames i.e. within the DwPTS fields of the special subframes.
Secondary Synchronisation Signal S-SS	Enables frame synchronisation by the user equipment and provides cell identity information during cell search. Transmitted on 62 subcarriers around the centre DC subcarrier. It occurs twice per frame: on the second last symbol in slots 0 and 10 in FDD frames, and on the final symbol in subframes 0 and 5 in TDD frames.
Reference Signal RS	Enables channel estimation by the user equipment. Reference signals consist of single symbols distributed throughout the LTE signal in any one of 510 possible sequences. They occur as a single symbol every sixth subcarrier in the frequency domain. In the time domain they occur on two symbols per slot for antenna ports 0 and 1 or on one symbol per slot for antenna ports 2 and 3.
LTE DOWNLINK PHYSICAL CHANNELS	
Physical Broadcast Channel PBCH	Broadcasts parameters essential for initial cell access, e.g. system bandwidth. Transmitted on 62 subcarriers around the centre DC subcarrier. It occurs once per frame: on the first four symbols in slot 1.
Physical Downlink Control Channel PDCCH	Carries the resource assignment for the user equipment. Transmitted on up to three symbols in the first slot of each subframe.
Physical Downlink Shared Channel PDSCH	Carries the user data. Transmitted in every subframe when data is being sent.

Table 16 - LTE Downlink Physical Signals and Channels

127. The P-SS, S-SS, PBCH and RS are of particular interest in the context of NIR emissions measurement. These signals are always transmitted in the downlink regardless of whether data traffic is present or whether user devices are connected. As such, they are suitable for measurement and consequent extrapolation to the emission level resulting from the downlink under maximum data traffic.

Spectral Measurement Method

128. The measurement approach, including parameters to be used on the spectrum analyser, is summarised in Table 17 and explained in further detail below.

Trace Mode	Max Hold
Detector	RMS
RBW	1 MHz
VBW	≥3 MHz
Sweep Time	100 ms
Measurement Duration	No. of Horizontal Trace Pixels on Analyser Display × 70 μs
Measurement Mode	Time Domain (e.g. Zero Span)
Extrapolation for Max Traffic Load	<p>Note the full bandwidth of the LTE signal being measured by inspection in the frequency domain.</p> <p>Calculate the level for maximum traffic E_{MAX} by applying a correction factor to the measured level E_{MEAS} to extrapolate from 1 MHz to the full bandwidth of the signal:</p> $E_{MAX} = E_{UMTS} \times K_{RBW} \times \sqrt{n_{p-cpich}} \quad (V/m \text{ Calculation})$ <p>Where</p> $K_{RBW} = \sqrt{B_{Signal}/B_N}$ <p>and B_{Signal} = signal bandwidth</p> <p>B_N = noise bandwidth of the analyser filter</p> <p>(for a Gaussian Filter: B_N ≈ 1.1 × B_{3dB})</p>
TDD LTE Extrapolation for Max Downlink Duty Cycle	<p>In the case of TDD LTE signals only, it is necessary to normalise the time averaged (RMS) level to the maximum downlink duty cycle:</p> $E_{TDD \text{ down max duty}} = E_{MAX} \times K_{TDD \text{ down max duty}}$ <p>Where</p> <p>E_{MAX} is the maximum traffic level calculated as per above</p> <p>K_{TDD down max duty} is the correction factor for the maximum downlink duty cycle of the TDD LTE signal.</p>

Table 17 - LTE Spectral measurement method

129. The basic approach is to measure always on channels/signals within the full LTE signal, which are sufficiently wideband and independent of traffic load i.e. P-SS, S-SS and PBCH (Figure 15). Frequency domain scans of the relevant frequency bands with the spectrum analyser at the point of maximum field strength (as determined by the initial site survey) near the designated transmitter site will show what LTE signals are present on which frequency. Each LTE signal detected must then be measured individually with the analyser in zero span.

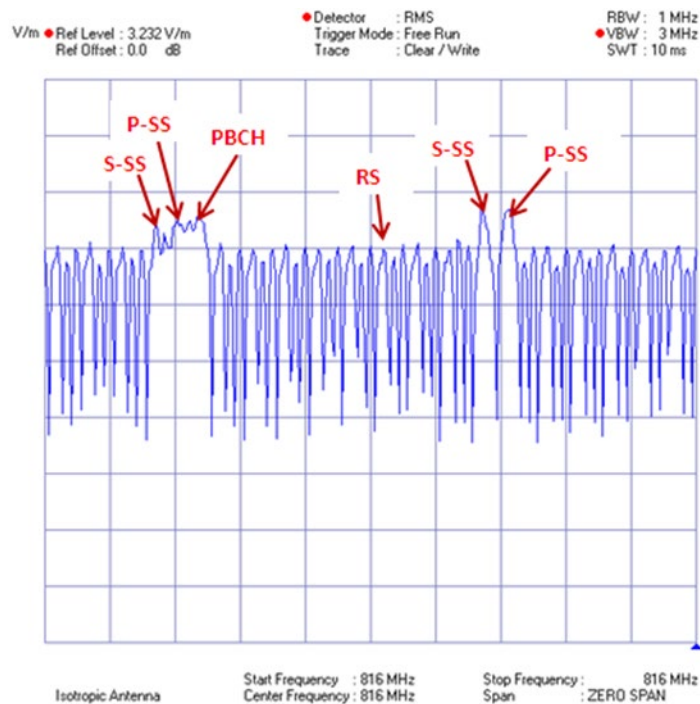

Figure 15 - LTE FDD downlink signal without traffic. Time domain over 10ms (LTE frame duration)

Detector

130. LTE signals exhibit a large crest factor i.e. short duration instantaneous values can be seen to occur in the time domain, which clearly lie above the average power (Wuschek 2012, p. 30), as illustrated in Figure 16. Measurements at LTE base stations indicate that the crest factor can be between 9 and 12 dB above the average power (Bornkessel et al, 2012, p. 42). Measuring the crest factor of such a signal with peak detector on the spectrum analyser would overstate the level of the emission. In any case, the ICNIRP 2020 Guidelines specify reference levels in terms of unperturbed RMS values. As such, the RMS detector is best suited for measurement of LTE signals.

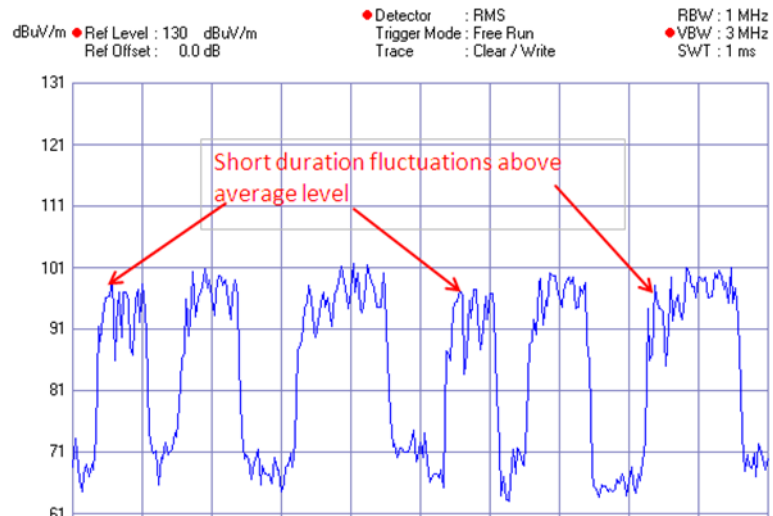

Figure 16 - LTE FDD downlink signal without traffic. Time domain over 1ms (14 symbols)

Resolution Bandwidth (RBW)

131. The always on P-SS, S-SS and PBCH channels sit within the centre of an LTE signal and are approximately 1 MHz wide: 0.95 MHz in case of the P-SS and S-SS and 1.10 MHz in the case of the PBCH, when the centre DC subcarrier is included. An RBW of 1 MHz will be sufficient to perform measurements of these channels accurate within a small margin of -0.3 to 0.4 dB (Bornkessel et al, 2012, p. 45).

Video Bandwidth (VBW)

132. Too narrow a VBW will remove too much noise in the detector output and affect the accuracy of results by up to 2.51 dB when using the RMS detector (Rauscher et al, 2008, p. 70). To avoid this, the VBW should be set to at least three times the RBW. Thus, measuring the P-SS, S-SS and PBCH channels with an RBW of 1 MHz will require a VBW of at least 3 MHz.

Sweep Time

133. Applying a suitable sweep time is important for satisfactory measurement of the pulses representing the symbols within the LTE signal.

134. Increasing the sweep time means that the dwell time in a frequency or time range allocated to a pixel on the analyser display also increases (Rauscher et al, 2008, p. 68). If too large a sweep time is selected, the dwell time will be longer than the duration of the pulses carrying the symbols within the LTE signal. In such a case, the analyser may under-calculate the RMS signal level by taking into account sample values from times where no signal is present (Bornkessel, 2011, p. 13), e.g. adjacent 'blank' pulses in the time domain (i.e. a subcarrier is not on) which can occur for channels such as the PDSCH when no user data is being transmitted.
135. At the same time, the dwell time must not be too short, as too few samples of the pulse will be available to calculate the RMS value reliably. Depending on the analyser make and model, confidence in RMS measurement accuracy increases with the number of samples (Bornkessel et al, 2012, pp. 47-48). LTE symbol lengths can vary from 71.4 μ s (normal CP) to 88.3 μ s (extended CP) or 100 μ s for MBMS data. As such, selecting a longer dwell time than the shortest possible LTE symbol duration of 71.4 μ s would increase the likelihood of underestimating the RMS level, while selecting a shorter dwell time means less confidence in the precision of the measurement. Bornkessel (2011, p. 13) recommends a dwell time of 70 μ s per trace pixel on the spectrum analyser display.
136. An optimum dwell time of 70 μ s per trace pixel on the analyser means that the total sweep time to be selected depends on the number of horizontal trace pixels on the analyser display. Thus, for an analyser with a horizontal resolution of 320 trace pixels, the sweep time will be $320 \times 70 \mu\text{s} = 22.4 \text{ ms}$. The horizontal resolution and sweep times for commonly used devices for measuring non-ionising radiation emissions are shown in Table 18.

Analyser	Channel	Signal Bandwidth
Rohde & Schwarz FSH 3/6/18 (2008 models)	320	22.4
Rohde & Schwarz FSH 4/8/13/20	640	44.8
Narda SRM 3006	800	56.0

Table 18 - Indicative sweep times for LTE signal measurement

Measurement Mode

137. The P-SS and S-SS are each transmitted every 5 ms (twice per frame), while the PBCH is transmitted every 10 ms (once per frame). As the required sweep times on spectrum analysers are typically much greater than the frame duration, e.g. 22.4 ms or more compared to 10 ms frames, detecting these channels becomes difficult in the frequency domain.
138. For example, in the frequency domain, an analyser with a horizontal resolution of 320 trace pixels and a set sweep time of 22.4 ms will sweep across the set frequency span, dwelling on each pixel for 70 μ s. The detector will only dwell on the pixel representing the centre frequency once every 22.4 ms. As such, it is by no means certain that the P-SS, S-SS or PBCH will be detected, given that these channels occur much less frequently within a frame compared to the other channels.

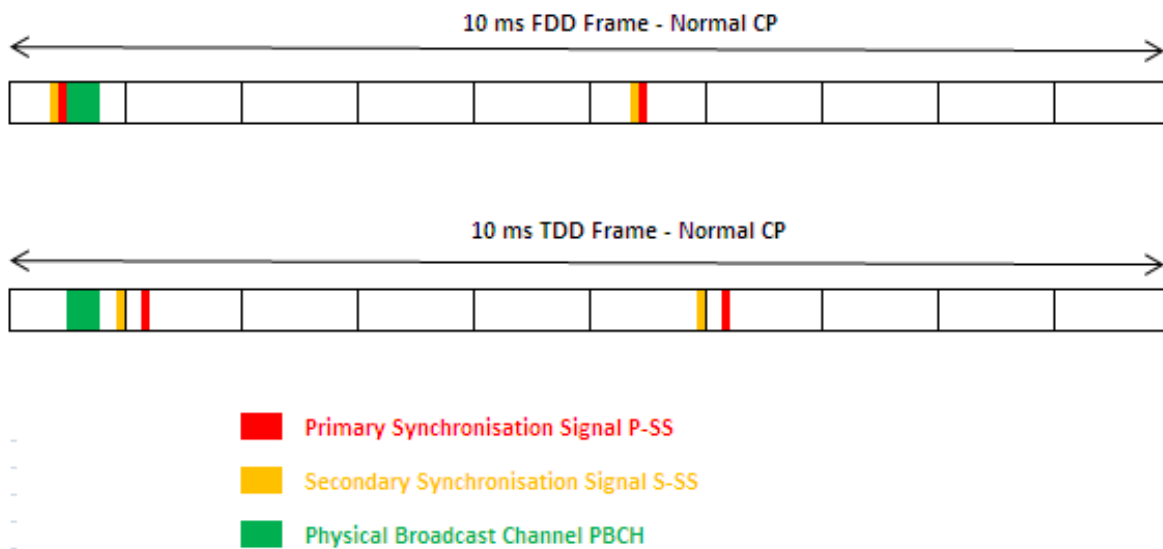

Figure 17 - Occurrence and positions of P-SS, S-SS and PBCH within LTE frames

139. Furthermore, it is extremely unlikely the analyser dwell time will be synchronised with the LTE symbol duration. In FDD frames, P-SS symbols follow S-SS symbols, but are separated in TDD frames. PBCH pulses occur two or four in succession in both FDD and TDD frames (Figure 17). If the dwell time commences within one symbol of the PBCH and ends within the next symbol or commences within an S-SS symbol preceding a P-SS symbol (in FDD), it will still allow for sufficient samples to be gathered to determine the RMS level. In order for a dwell time to occur somewhere within two successive symbols, successive dwell times must occur on the same centre frequency from which the level is read.

140. For these reasons, time domain measurement (e.g. zero span) is more appropriate than frequency domain measurement for detecting and measuring the always on wideband channels of the LTE signal.

Extrapolation to Max Traffic Load

141. Determining the emission level under maximum traffic load involves extrapolating from the level measured for the always-on subcarriers of the P-SS, S-SS and PBCH channels across 1 MHz to what the level would be if all the subcarriers across the full signal bandwidth were being transmitted and carrying data.
142. The LTE standard defines six possible channel bandwidths ranging from 1.4 to 20 MHz. However, the actual bandwidth occupied by a signal is less than the defined channel bandwidth, as shown in Table 19.

Channel Bandwidth (MHz)	Signal Bandwidth (MHz)
1.4	1.08
3	2.7
5	4.5
10	9
15	13.5
20	18

Table 19 - LTE Downlink Channel and Signal Bandwidths

143. The full bandwidth of the LTE signal being measured should be noted by inspection in the frequency domain and with reference to the possible signal bandwidths shown in Table 19. To extrapolate to a level E_{MAX} for maximum traffic load across the full signal bandwidth, a correction factor is applied to the measurement to extrapolate from an RBW of 1 MHz to the full bandwidth of the signal:

$$E_{MAX} = E_{MEAS} \times K_{RBW} \quad (V/m \text{ Calculation})$$

Where

$$K_{RBW} = \sqrt{B_{Signal}/B_N}$$

And B_{Signal} = signal bandwidth

B_N = noise bandwidth of the analyser filter (for a Gaussian Filter: $B_N \approx 1.1 \times B_{3dB}$)

Example Spectral Measurement

144. The following example (Figure 18) shows an LTE downlink signal in the frequency domain centred on 816 MHz with a signal bandwidth of 9 MHz.

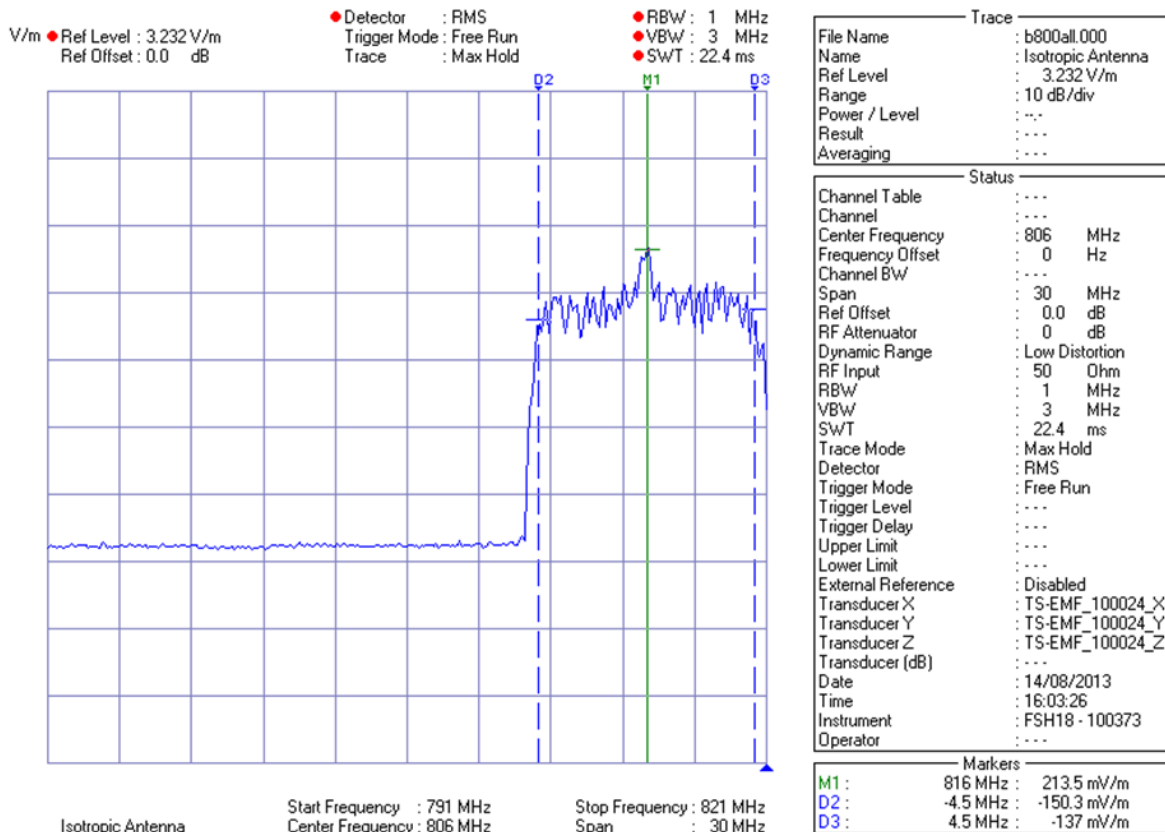

Figure 18 - LTE downlink signal on centre frequency 816 MHz (signal bandwidth 9MHz)

145. The signal is then measured with an RBW of 1 MHz in the time domain. i.e. on zero span (Figure 19). As the spectrum analyser display has a horizontal pixel resolution of 320 trace pixels, the sweep time to apply is $320 \times 70 \mu s = 22.4$ ms.

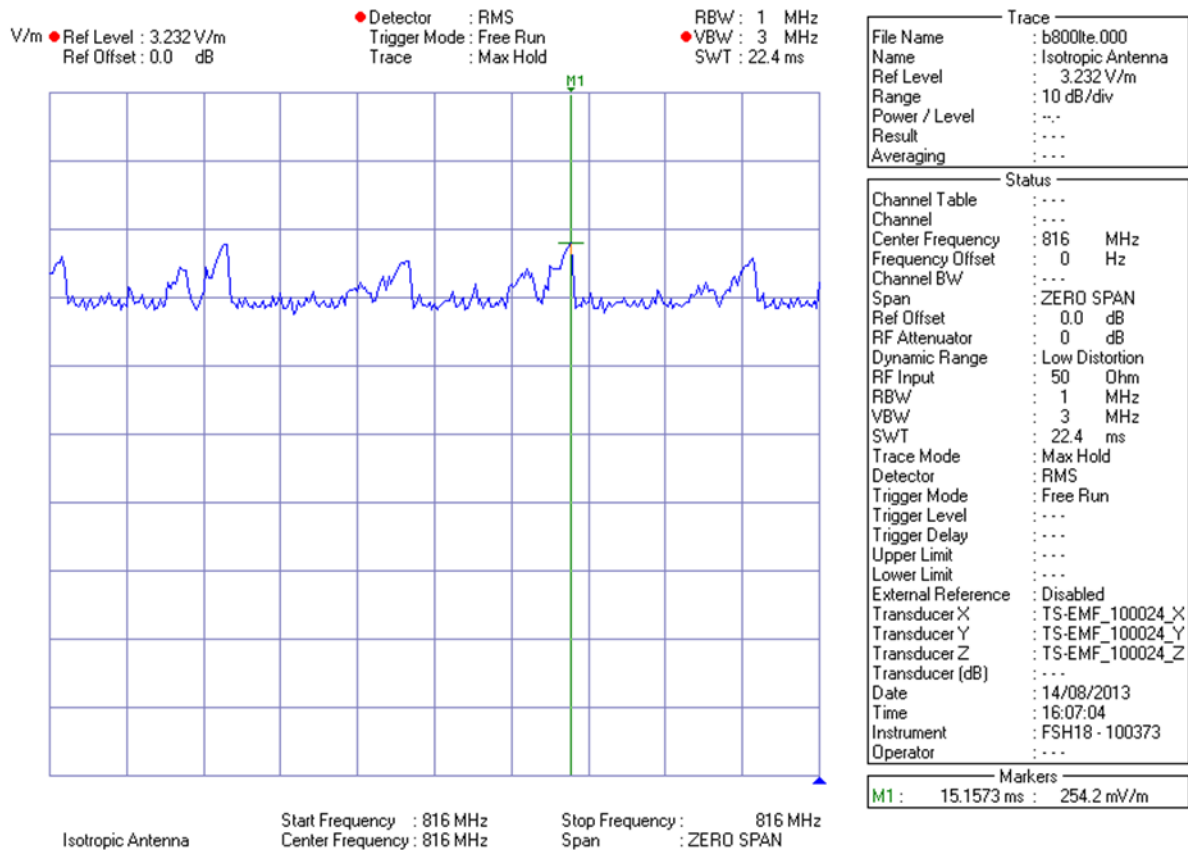

Figure 19 - Time domain (zero span) measurement of LTE signal on 816 MHz

146. Setting the marker to peak shows the highest level attributable to one of the always on channels, 254.2 mV/m. To calculate E_{MAX} for maximum traffic load, the correction factor for the 9 MHz wide signal is:

$$K_{RBW} = \sqrt{9/(1.1 \times 1)} = 2.86$$

Thus: $E_{MAX} = 0.2542 \times 2.86 = 0.7271 \text{ V/m}$

147. The results may be tabulated as follows:

Emission Type	Frequency		Measured E-	Adjusted E-Field		
	Frequency (MHz)	ICNIRP Limit (V/m)	Measured Level (V/m)	Max Traffic Extrapolation Factor	Est. Max Traffic Level (V/m)	Times below Limit
LTE	816	39.3	0.2542	2.86	0.7271	54

Table 20 - Table of example LTE spectral measurement results

Code Selective Measurement Method

148. Code selective measurement allows separation of each RS from each sector and each antenna port within each sector and measurement of each individually. RS are coded differently for each sector (cell) of an LTE base station and are distributed in different positions within the resource grid for each antenna port (Figure 20).

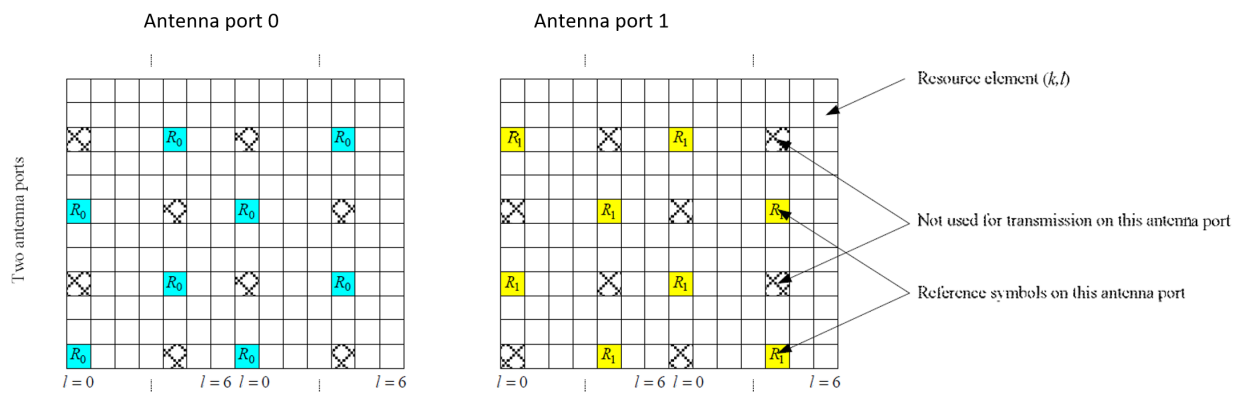

Figure 20- Reference signal distribution for antenna ports 0 and 1²⁹

149. Because the RS are independent of traffic load, they can be used to extrapolate to the emission level for each signal at maximum traffic load. Some commercially available spectrum analysers and frequency selective radiation meters have an optional mode for code selective measurement of LTE signals. The implementation of code selective measurement may be different for the devices of different manufacturers. However, the basic procedure is as follows:

- (1) Firstly, on the analyser select the centre frequency of the LTE signal to be measured.
- (2) For accurate measurement, such that the levels of the RS are averaged across the full signal bandwidth in the frequency domain, if device settings permit, the channel bandwidth (CBW) selected on the device should match the channel bandwidth of the LTE signal being measured. E.g. A CBW of 10 MHz should be selected for a signal with a channel bandwidth of 10 MHz.

²⁹ Source ETSI TS 136 211 V13.3.0, p. 104

- (3) Measure the individual levels for each RS from each cell and antenna port within each cell. Depending on the measurement device, these may all be displayed simultaneously, or it may be necessary to measure each one-by-one.
- (4) As the level measured for an RS relates to a single resource element on a 15 KHz wide subcarrier, an extrapolation must be performed to the maximum operating load for each LTE downlink signal. As such, the extrapolation factor depends on the number of subcarriers in the signal being measured (see Table 14). Given that the number of subcarriers varies according to the channel bandwidth of the signal, the extrapolation factor therefore depends on the number of subcarriers making up the LTE signal. In the case of an LTE signal with a channel bandwidth of 10 MHz, which consists of 600 subcarriers, an extrapolation can be made to the full power of the signal as 600 times the power of the average reference signal. Thus, for electric field strength measurement in V/m, the extrapolation factor is:

$$K_{FULL} = \sqrt{NUM_{subcarriers}}$$

where $NUM_{subcarriers}$ = the width of the LTE signal in 15 kHz subcarriers

Thus, for each separately coded signal on the channel, the level at maximum traffic load will be:

$$E_{i,MAX} = E_{RS_{i,meas}} \times K_{FULL} \quad (V/m \text{ Calculation})$$

Where $E_{RS_{i,meas}}$ = average level in V/m of each separately coded reference signal

The levels for each signal are then summed to give the total combined level for all emissions from all sectors/antenna ports on the same centre frequency for comparison with the relevant reference level:

$$E_{MAX} = \sqrt{\sum_i E_{i,MAX}^2}$$

Special considerations for TDD LTE signals

150. In the case of TDD LTE signals only, it is necessary to apply a further correction factor to the level at maximum traffic load for each separately coded signal on the channel in order to normalise the time averaged (RMS) level to the maximum downlink duty cycle. Thus, for each separately coded signal on the channel, the level at maximum downlink duty cycle of the TDD signal will be:

$$151. \quad E_{i,TDD \text{ down max duty}} = E_{i,MAX} \times K_{TDD \text{ down max duty}}$$

where

$E_{i,MAX}$ is the maximum traffic level calculated as per above, and

$K_{TDD \text{ down max duty}}$ is the correction factor for the maximum downlink duty cycle of the TDD LTE signal, determined as per subsection 8.8.5. Please note that different correction factor values might apply to each separately coded signal on the channel if they are each using different special subframe configurations.

152. For TDD LTE, the total combined level for all emissions from all sectors/antenna ports on the same centre frequency is then calculated as follows:

$$E_{MAX} = \sqrt{\sum_i E_{i,TDD \text{ down max duty}}^2}$$

Example Code Selective Measurement

153. The following example (Figure 21) shows an LTE downlink signal in the frequency domain centred on 816 MHz with a channel bandwidth of 10 MHz and a signal bandwidth of 9 MHz.

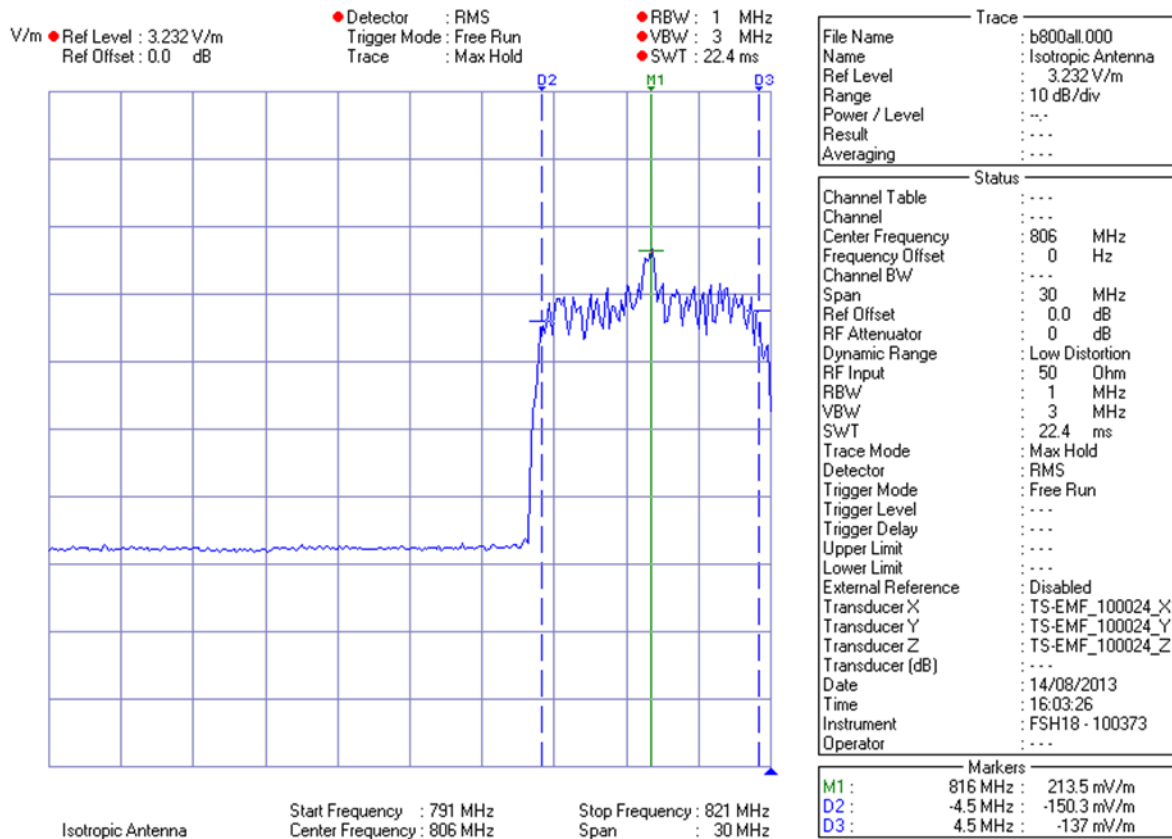

Figure 21 - LTE downlink signal on centre frequency 816 MHz (signal bandwidth 9MHz)

154. The RS from each cell and antenna port present within the overall emission are then measured with a CBW of 10 MHz in the code domain Figure 22 shows measurement results as they might appear on the analyser display.

Index	Cell ID	No. Ant	Max (RS 0)	Max (RS 1)
1	158	2	88.12 dBµV/m	89.01 dBµV/m
2	159	2	91.32 dBµV/m	90.94 dBµV/m
Total			93.02 dBµV/m	93.09 dBµV/m
Fcent:		816 MHz		

Figure 22 - Code domain measurement results for LTE signal on 816 MHz

155. Given a 9 MHz signal bandwidth (600 subcarriers wide), the extrapolation factor to calculate the maximum traffic emission level for each separately coded signal is:

$$K_{FULL} = \sqrt{600} = 24.49$$

Thus, for each separately coded signal on the channel, the level at maximum traffic load will be:

$$E_{i,MAX} = E_{RSi,meas} \times 24.49$$

156. The maximum traffic levels, E_i, MAX , for each separately coded signal are then summed to give the total combined level, E_{MAX} , for all emissions from all cells/antenna ports on the same centre frequency. This combined level can then be compared to the relevant reference level. A tabulation of the measurement results is shown in Table 21.

Emission Type	Frequency (MHz)	Cell ID/RS	Measured E-Field		Adjusted E-Field			
			Measured Level RS (dBµV/m)	Measured Level RS (V/m)	Max Traffic Extrapolation Factor	Est. Max Traffic Level (V/m)	Est. Max Traffic Level (V/m)	Times below Limit
LTE	816	158/RSO	88.12	0.0255	24.49	0.6238	39.3	63
LTE	816	158/RSO	89.01	0.0282	24.49	0.6912	39.3	57
LTE	816	158/RSO	91.23	0.0368	24.49	0.9017	39.3	44
LTE	816	158/RSO	90.94	0.0352	24.49	0.8631	39.3	46
			Total	0.0636		1.5572	39.3	25

Table 21 - Tabulation of example LTE code selective measurement results

EPRE ratios correction factor

157. Bornkessel (2011, p. 14) outlines an additional correction factor to account for possible differences in transmission power between the Resource Elements of the different physical channels/signals within an LTE signal. This correction factor can be applied to the extrapolated emission level for maximum data traffic.
158. If the Resource Elements of all channels and signalisation (e.g. RS, P-SS, PDSCH etc.) within the LTE signal are transmitted with equal power, the maximum traffic extrapolation factor used in the spectral and code selective measurement methods will be sufficient to derive the field strength of the signal under maximum traffic load. However, at some base stations the power of the resource elements of some channels within the LTE signal may be boosted relative to those of other channels. The EPRE (energy per resource element) settings for the base station specify whether the resource elements of all channels within the LTE signal are transmitted with equal or varying power.
159. Such EPRE boosting is used to facilitate easy detection and demodulation of the RS as well as of synchronisation and control channels. Spectral measurement relies on measuring the P-SS, S-SS or PBCH, while code selective measurement is based on the RS. As such, at base stations where EPRE boosting is in use, measuring the RS or P-SS/S-SS or PBCH will lead to an overestimation of the average emission level when the correction factor for maximum traffic is applied. As long as the extrapolated level for emissions under maximum traffic is below the reference level, this is not an issue.
160. Typically, within a base station the EPRE settings for each signal are specified as values relative to the EPRE of the RS. If the EPRE settings of the base station are available from the network operator, a further correction factor ($K_{EPREratios}$) can be determined to account for any power differences between channels within a signal. The correction factor for E-field measurements is calculated as follows:

$$K_{EPREratios} = \sqrt{\sum_i (count_re_chan_i \times epre_ratio_chan_i)}$$

where, for each physical channel or signal i within an LTE downlink signal:

- $count_re_chan_i$ = the number of resource elements representing the physical channel or signal i within the resource grid of a single frame of an LTE signal

- epr_ratio_chani = the ratio of the EPRE of the RS to the EPRE of a physical channel or signal i

161. This correction factor is best explained by way of an example. Code selective measurement might be conducted at a base station where the EPRE settings specify that the EPRE of the RS is boosted by 3dB, or a factor of 2, relative to the EPREs of the other physical channels/signals. If an FDD LTE signal using normal CP from the base station has a channel bandwidth of 10 MHz, a single frame of the signal will consist of 600 carriers in the frequency domain and 140 symbols in the time domain. Thus, the number of Resource Elements in a frame will be $600 \times 140 = 84000$.

162. Given that RS occur every sixth subcarrier in the frequency domain and in two symbols per slot (with 20 slots per frame) in the time domain, the number of RS in a frame is:

$$(600/6) \times (2 \times 20) = 4000$$

Therefore, the number of Resource Elements occupied by other physical channels/signals is:

$$84000 - 4000 = 80000$$

Therefore, the number of Resource Elements occupied by other physical channels/signals is:

$$K_{EPREratios} = \sqrt{[(4000 \times 1) + (80000 \times 0.5)]/84000} = 0.724$$

163. Given that detailed EPRE settings must be acquired from operators in respect of multiple base stations, applying $K_{EPREratios}$ may not be feasible in practice. Furthermore, in the case of spectral measurement, it may be difficult to apply if LTE signals on the same channel from other sectors on the same base station or from other base stations are present at the measurement point. If each base station has different EPRE settings, a separate $K_{EPREratios}$ will need to be calculated and applied to the different signals. However, spectral measurement does not separate out these signals and detects rather an aggregate level of all the signals. Only code selective measurement offers the facility to disentangle each of these signals and apply $K_{EPREratios}$ reliably.

TDD LTE: Correctio Factor for Maximum Downlink Duty Cycle

164. In the case of TDD LTE signals, the maximum possible duty cycle on the downlink is not 100%. As such, it is necessary to apply a correction factor to the measured field strength as extrapolated to maximum traffic load in order to normalise it to the duty cycle and in order not to overestimate the time averaged (RMS) field strength over several minutes for comparison with the ICNIRP 2020 limits.
165. The maximum possible downlink duty cycle of a TDD LTE signal corresponds to the maximum possible duration of downlink transmission within a frame as a proportion of total TDD LTE frame duration:

$$\text{TDD LTE downlink max duty cycle} = t_{\text{downlink max frame}}/T_{\text{frame}}$$

Where:

$t_{\text{downlink max frame}}$ = maximum possible duration of downlink transmission within a frame

T_{frame} = the duration of the full TDD LTE frame, i.e. 10 ms

Thus, the correction factor to apply to a measured field strength as extrapolated to maximum traffic duty cycle can be calculated as follows:

$$K_{\text{TDD down max duty}} = \sqrt{t_{\text{downlink max frame}}/T_{\text{frame}}}$$

166. In order to determine the maximum possible duration of downlink transmission within a frame, it is first necessary to consider the uplink-downlink configurations for TDD LTE frames supported by the LTE standard³⁰. The uplink-downlink configuration in a cell may vary between frames and controls in which subframes uplink or downlink transmissions may take place in the current frame. The LTE standard supports seven uplink-downlink configurations for Type 2 TDD frames, as shown in Table 22, where, for each subframe in a frame, "D" denotes a subframe reserved for downlink transmissions, "U" denotes a subframe reserved for uplink transmissions and "S" denotes a special subframe with three fields: downlink pilot timeslot (DwPTS), guard period (GP) and uplink pilot timeslot (UpPTS).

³⁰ ETSI TS 136 211 V13.3.0, pp. 15-16

Uplink-downlink configuration	Downlink-to-Uplink switch-point periodicity	Subframe number									
		0	1	2	3	4	5	6	7	8	9
0	5ms	D	S	U	U	U	D	S	U	U	D
1	5ms	D	S	U	U	D	D	S	U	U	D
2	5ms	D	S	U	D	D	D	S	U	D	D
3	10ms	D	S	U	U	U	D	D	D	D	D
4	10ms	D	S	U	D	D	D	D	D	D	D
5	10ms	D	S	U	D	D	D	D	D	D	D
6	5ms	D	S	U	U	U	D	S	U	U	D

Table 22 - TDD LTE Uplink-downlink configurations³¹

167. From Table 22, it can be seen that the maximum possible duty cycle on the downlink from an LTE TDD base station corresponds to uplink-downlink configuration 5 which has the most subframes (eight) dedicated to downlink transmission. Thus, the maximum possible duration of downlink transmission within a frame can be calculated from the length of eight subframes (i.e. 8 ms) plus the length of the DwPTS occurring within the special subframe:

$$t_{downlink\ max\ frame} = 8\ ms + DwPTS\ length\ (ms)$$

168. The DwPTS length can vary and depends on the cyclic prefix length (normal or extended CP) and the special subframe configuration (0 to 9 as specified in the LTE standard) in use. Based on the DwPTS lengths specified in the LTE standard for each special subframe configuration and cyclic prefix, the range of possible duty cycles and corresponding correction factors for uplink-downlink configuration 5 can be calculated, as shown in Table 23.

Serial subframe configuration	Normal DP in downlink			Extended CP in downlink		
	DwPTS Length (ms)	Duty Cycle	Correction Factor $K_{TDD\ down\ max\ duty}$	DwPTS Length (ms)	Duty Cycle	Correction Factor $K_{TDD\ down\ max\ duty}$
0	0.2146	0.8215	0.9063	0.2500	0.8250	0.9083
1	0.6432	0.8643	0.9297	0.6667	0.8667	0.9309
2	0.7146	0.8715	0.9335	0.7500	0.8750	0.9354
3	0.7859	0.8786	0.9373	0.8333	0.8833	0.9399
4	0.8573	0.8857	0.9411	0.2500	0.8250	0.9083
5	0.2146	0.8215	0.9063	0.6667	0.8667	0.9309
6	0.6432	0.8643	0.9297	0.7500	0.8750	0.9354
7	0.7146	0.8715	0.9335	0.4167	0.8417	0.9174
8	0.7859	0.8786	0.9373	-	-	-
9	0.4286	0.8429	0.9181	-	-	-

³¹ Source ETSI TS 136 211 V13.3.0, p. 16, Table 4.2-2

Table 23 - Correction factors by special subframe configuration and cyclic prefix³²

169. If it is not possible to determine the special subframe configuration, then the highest possible duty cycle should be assumed and the highest correction factor should be applied, i.e. 0.9411 for normal CP or 0.9399 for extended CP. It should be noted in the measurement report that it was not possible to determine the special subframe configuration used in the TDD LTE signal and, therefore, the corresponding correction factor to apply, and that the level reported may represent an overestimation of the RMS level for the maximum duty cycle. However, if aggregate emissions are found to exceed the Reference Levels, a determination of the RMS level for the LTE TDD downlink signal at its maximum possible duty cycle based on the appropriate correction factor for the subframe configuration in use is necessary for an accurate and justifiable measurement.

³² Calculated from Table 4.2-1 in ETSI TS 136 211 V13.3.0, p. 16

8.9 WIFI

170. WIFI networks, operating according to IEEE 802.11 protocols, are by now a ubiquitous technology, to be found in homes, offices, coffee shops, airports, hotels, conference centres and many public venues. As such, WIFI signals have become a fixed feature of the spectrum landscape, especially in urban and suburban areas.

171. The widely anticipated deployment by mobile operators of heterogeneous networks (HetNets) in the coming years will most likely lead to a further expansion in the number of WIFI nodes. A HetNet is typically composed of multiple radio access technologies (GSM, UMTS, LTE etc.) and can expand mobile network capacity by offloading data traffic to WIFI.

172. In Ireland, as in most of Europe, WIFI operates in the 2.4 and 5 GHz frequency bands in accordance with the channel plans specified in the IEEE 802.11 set of standards (Table 24).

Band	2.4 GHz		5 GHz (indoor use only)		5GHz	
Frequency Range	2400 – 2483.5 MHz		5150 – 5350 MHz		5470 – 5725 MHz	
Max EIRP	100 mW		200 mW		1 W	
	Channel Number	Centre Frequency MHz	Channel Number	Centre Frequency MHz	Channel Number	Centre Frequency MHz
	1	2412	36	5180	100	5500
	2	2417	40	5200	104	5520
	3	2422	44	5220	108	5540
	4	2427	48	5240	112	5560
	5	2432	52	5260	116	5580
	6	2437	56	5280	120	5600
	7	2442	60	5300	124	5620
	8	2447	64	5320	128	5640
	9	2452			132	5660
	10	2457			136	5680
	11	2462			140	5700
	12	2467				
	13	2472				

Table 24 - WIFI bands and channel plans

173. The current widely deployed WIFI standards, IEEE 802.11a/b/g/n, allow for signal bandwidths of up to 40 MHz (Table 24). The new IEEE 802.11ac draft standard (due for final ratification during 2014) provides for extra throughput in the 5 GHz band on 80 MHz channels and also on optional 160 MHz channels consisting of two contiguous or non-contiguous 80 MHz channels. In addition, the IEEE 802.11ad "WiGig" standard, released in 2013, extends WIFI to the 60 GHz band (57.25 – 65.88 GHz) aimed at providing multi-gigabit speed data transfer and covering a very short range (up to 10 m).

Modulation	IEEE 802.11 a/b/g/m			IEEE 802.11 ac	
	DSSS	OFDM	OFDM	OFDM	OFDM
Channel Bandwidth	22 MHz	20 MHz	40 MHz	80MHz	160 MHz (contiguous or non-contiguous 80 + 80 MHz)
Signal Bandwidth	22MHz	16.56 MHz	33.75MHz	67.5MHz	67.5 + 67.5
* Signal bandwidths for 80 and 160 MHz channels are estimated					

Table 25 - WIFI channel and signal bandwidths

Measurement procedures

174. Two procedures for measuring WIFI emissions, time and frequency domain, are outlined below. Time domain measurement gives more accurate results and, as such, is recommended when measuring emissions from a site where WIFI signals most likely constitute the dominant component of the aggregate electromagnetic field, e.g. at a WIFI hotspot very close to the access point.
175. In other situations where, for example, numerous low power WIFI signals from various nearby premises and houses are detectable outdoors, measuring each signal individually in the time domain can be very time consuming. Instead it may be more practical to conduct measurements in the frequency domain by means of sweeps of each WIFI band with a spectrum analyser. As the frequency domain measurement method only permits measurements of signal peak rather than RMS levels, it will most likely overstate the emission level due to the high peak-to-average ratio (or crest factor) of the OFDM signals typically used for WIFI. As long as the aggregate level of emissions is below the Reference Levels this is not an issue. However, should the aggregate level of emissions exceed the Reference Levels, then each WIFI signal detectable at the measurement point must be measured individually in the time domain to give a more accurate and justifiable measurement.
176. In both time and frequency domain methods, measurements are performed on the centre frequency of each WIFI signal apparent at the measurement point³³. Both methods involve measuring the 'always-on' beacon frames within WIFI signals. A WIFI access point transmits beacon frames (0.25 ms long) every 100 ms (Figure 23).

³³ **NB:** In cases where a WIFI channel is an aggregate of two adjacent channels, each channel should be measured separately (e.g. an optional 160 MHz channel consisting of two contiguous 80 MHz channels in IEEE 802.11ac).

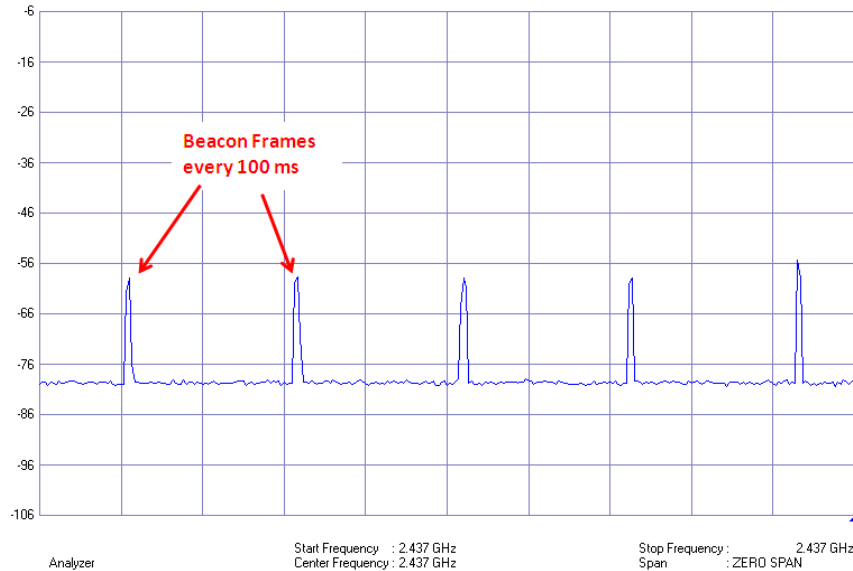

Figure 23 - Beacon frames for a WIFI access point in time domain

177. Any data is transmitted in the intervals between the beacon frames (Figure 24). However, data is not transmitted continuously and the occupancy by data frames of the gaps between beacon frames can vary according to factors such as data traffic intensity.

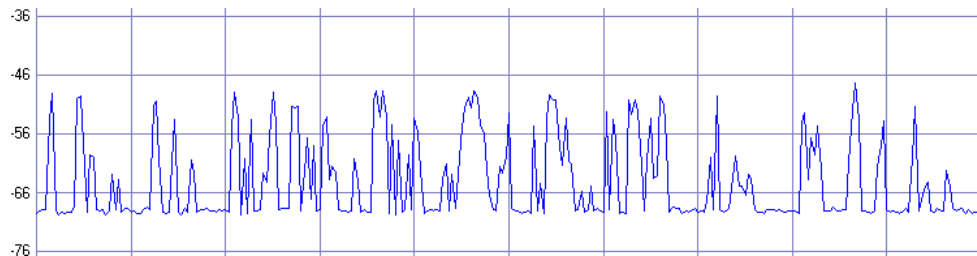

Figure 24 - WIFI signal in time domain with data transmitted between beacon frames

178. During a measurement it may be the case that little or even no data is being transmitted. As such, time averaging of exposure may understate exposure under maximum data traffic as the observed duty cycle may be low. On the other hand, a max hold measurement of beacon frames will overstate exposure as the duty cycle of a WIFI signal is not 100%. In order to give a ‘worst case’ exposure assessment of WIFI signals, a correction factor for extrapolation from measured beacon frame levels to a time averaged level based on a maximum duty cycle is outlined below.

Time Domain Measurement Method

179. The measurement approach, including parameters to be used on the spectrum analyser, is summarised in Table 26 and explained in further detail below.

Trace Mode	Max Hold
Detector	RMS
RBW	<ul style="list-style-type: none"> • Sufficient to cover signal bandwidth or • Narrower than signal bandwidth if RBW correction factor is applied as per Appendix 3. (For analysers with available RBWs narrower than signal bandwidth)
VBW	3 × RBW
Sweep Time	No of horizontal trace pixels on analyser display × 0.125 ms
Measurement Duration	A sufficient number of sweeps to display stable signal levels on the analyser screen
Measurement Mode	Time Domain (e.g. Zero Span)
Extrapolation for Max Traffic Load	$E_{\max \text{ mean duty cycle}}^{RMS} = E_{\text{beacon meas}}^{\max \text{ hold}} \times \sqrt{0.8741}$

Table 26 – WIFI time domain measurement method

180. With this method, each WIFI signal detectable must be measured separately in the time domain. The basic approach is to measure the RMS level of beacon frames and to extrapolate that level to the RMS level for the maximum duty cycle. Measurements are performed with the analyser set to the centre frequency of each WIFI signal present. The channel plan outlined in Table 24 can be used as a guide to determining centre frequencies.

181. Many commonly used spectrum analysers may not provide RBWs sufficient to cover the very wide bandwidths of WIFI signals (16.56 MHz upwards). A narrower RBW may be used and an RBW correction factor should be applied to the measurement to calculate a level for the full signal bandwidth as per Appendix 3.

182. Applying a suitable sweep time is important for satisfactory measurement of the RMS level of beacon frames within WIFI signals. When the spectrum analyser is in zero span mode for time domain analysis, each trace pixel on the horizontal axis of the display represents an interval of time (dwell time) which is a function of the sweep time and the number of horizontal trace pixels, i.e. Pixel Dwell Time = Sweep Time / No of Horizontal Trace Pixels.

183. If too long a sweep time is applied, the dwell time may be longer than the duration of a beacon frame. In such a case the analyser may under-calculate the RMS signal level by considering sample values from times where no signal is present e.g. when no data frames precede or follow a beacon frame. Furthermore, a sweep time which gives a pixel dwell time equal to the duration of a beacon frame (0.25 ms) will still be too long as, given that a sweep will most likely not be synchronised with beacon frame transmission, it cannot be guaranteed that the dwell time window will not include samples for times when the beacon frame is not being trans(Figure 25).

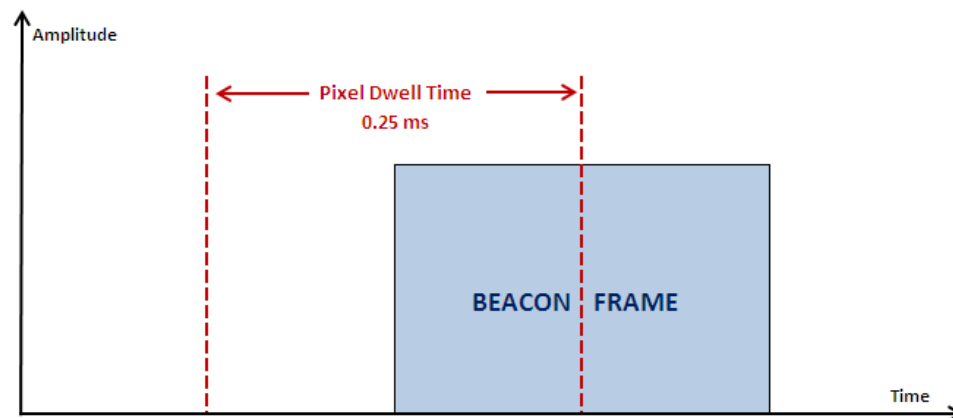

Figure 25 - Pixel dwell time = beacon frame duration, but out of synch

184. However, if the pixel dwell time is set to half of the beacon frame duration (at 0.125 ms), it becomes possible to capture continuous samples from the signal in the 'on' state. Even If a pixel dwell overshoots a beacon frame, the next dwell will lie entirely within the beacon frame and calculate an RMS level from the samples from the signal in the 'on' state (Figure 26).

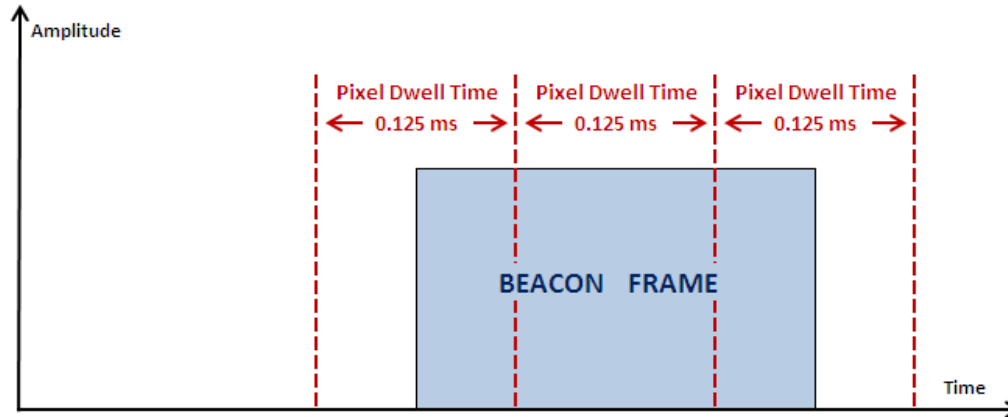

Figure 26 - Pixel dwell time set to half of beacon frame duration

185. An optimum dwell time of 0.125 ms per pixel on the analyser means that the total sweep time to be selected depends on the number of horizontal trace pixels on the analyser display. Thus, for an analyser with a horizontal resolution of 320 trace pixels, the sweep time will be $320 \times 0.125 = 40$ ms. The horizontal resolution and sweep times for commonly used devices for measuring non-ionising radiation emissions are shown in Table 27.

Analyser	Channel	Signal Bandwidth
Rohde & Schwarz FSH 3/6/18	320	40
Rohde & Schwarz FSH 4/8/13/20 (2013 models)	640	80
Narda SRM 3006	800	100

Table 27 - Indicative sweep times for WIFI time domain measurement

186. Once a stable level has been achieved the RMS level measured for the beacon frame is then extrapolated to an RMS level indicative of the WIFI signal at the maximum duty cycle by applying a suitable correction factor. (See note below on Extrapolation for Maximum WIFI Duty Cycle.)

Frequency Domain Measurement Method

187. In practice, especially in urban environments, where numerous extremely low power WIFI signals may be present, measuring each signal individually in the time domain will be very time consuming. Instead it may be more practical to conduct measurements via sweeps of each WIFI band with a spectrum analyser in the frequency domain.

188. The measurement approach, including parameters to be used on the spectrum analyser, is summarised in Table 28 and explained in further detail below.

Trace Mode	Max Hold
Detector	RMS
RBW	<ul style="list-style-type: none"> • Sufficient to cover signal bandwidth or • Narrower than signal bandwidth if RBW correction factor is applied as per Appendix 3. (For analysers with available RBWs narrower than signal bandwidth)
VBW	≥RBW
Sweep Time	No of horizontal trace pixels on analyser display × 100 ms
Measurement Duration	A sufficient number of sweeps to display stable signal levels on the analyser screen
Measurement Mode	Frequency domain
Extrapolation for Max Traffic Load	$E_{\max}^{RMS} \text{ mean duty cycle} = E_{\text{beacon meas}}^{\max \text{ hold}} \times \sqrt{0.8741}$

Table 28 - WIFI frequency domain measurement method

189. The basic approach is to measure the peak level of the beacon frames for each WIFI signal present. This level is then used to extrapolate an RMS level for the maximum possible duty cycle.

190. Many commonly used spectrum analysers may not provide RBWs sufficient to cover the very wide bandwidths of WIFI signals (16.56 MHz upwards). A narrower RBW may be used and an RBW correction factor should be applied to the measurement to calculate a level for the full signal bandwidth as per Appendix 3.

191. As the spectrum analyser sweeps across the band it will dwell for a fixed time on each frequency represented by pixels on the horizontal axis of the display. If the dwell time on a pixel is shorter than the beacon frame interval of 100 ms it may not detect a WIFI signal present on the relevant frequency, especially if no data traffic frames are transmitted between beacon frames. As such, beacon frames may not be detected on every frequency and the signal will appear fragmented (Figure 27). However, if the dwell time is equal to 100 ms the analyser will detect samples from at least one beacon frame during each pixel dwell even if no data is present and a coherent signal will be apparent (Figure 28).

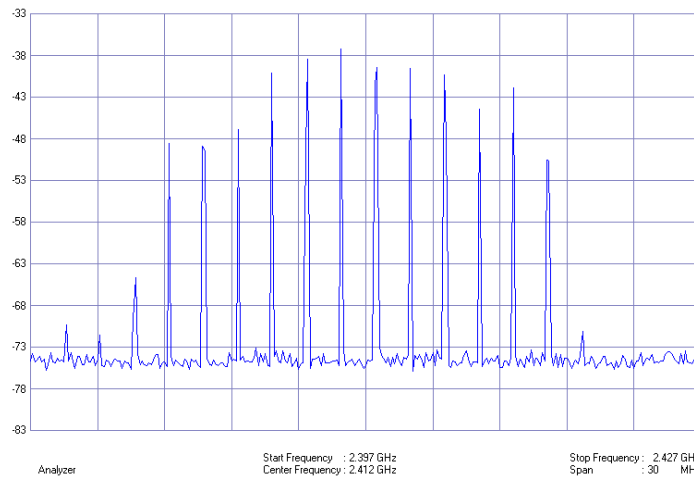

Figure 27 - pixel dwell time too short - fragmented signal

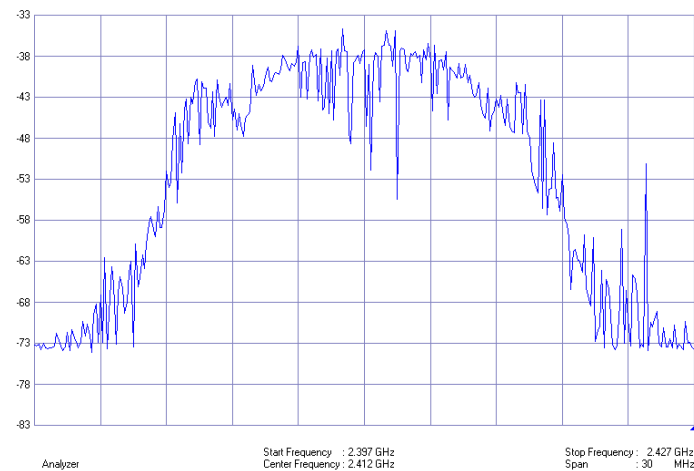

Figure 28 - 100 ms pixel dwell time - coherent signal

192. RMS detector is not suitable for this type of measurement as it will average measurement samples over 100ms not only from the beacon frames but also from the intervals between beacon frames where data traffic levels can vary. If data traffic is not present or low intensity, the analyser will report a low RMS level. However peak detector will capture the maximum signal levels, mostly attributable to beacon frames.
193. Once a stable trace of the band has been achieved after at least one sweep, the peak levels measured for the beacon frames for each WIFI signal present³⁴ are then extrapolated to an estimate of RMS level the WIFI signal averaged across the maximum duty cycle by applying a suitable correction factor. (See note below on Extrapolation for Maximum WIFI Duty Cycle.) It should be noted that, because the extrapolation is from the peak rather than RMS level of the beacon frame, this method will most likely overstate the emission level due to the high peak-to-average ratio of the OFDM signals typically used for WIFI.

Extrapolation for Maximum WIFI Duty Cycle

194. A max hold field strength measurement of the beacon frames overestimates the time averaged level as WIFI data is not transmitted continuously. In order to calculate a time averaged (RMS) field strength for comparison with the ICNIRP 2020 limits it is necessary to know the maximum possible duty cycle for WIFI signals which can be used to average the level over time for comparison with the limits.
195. In WIFI networks the basic access mechanism is carrier sense multiple access with collision avoidance (CSMA/CA). This means that each device accessing the network, including the access point (or router), will listen to the medium before transmitting. If a device detects a transmission is already in progress on the medium, the device will not begin a transmission, but will instead wait for a back-off time of random duration.
196. The random back-off, giving rise to an irregular duty cycle, makes channel occupation impossible to predict. As the duty cycle can vary according to traffic type (e.g. higher duty cycle for more data intensive video streaming compared to website browsing), the duty cycle observed when measuring emissions from a WIFI access point may not be indicative of the maximum possible duty cycle.

³⁴ The channel plan outlined in Table 23 can be used as a guide to determining centre frequencies for each channel.

197. Joseph et al (2013, p. 33) report a highest average duty cycle of 87.41% for file transfer based on measurements of WIFI duty cycles in different environments (office, residential, urban etc.) and for different types of traffic (website surfing, YouTube video, file transfer etc). This corresponds to a scenario of poor WIFI signal quality where lower modulation leads to a lower physical data rate and consequent longer transmit time. This highest average duty cycle can be used as a “realistic worst case” value for estimation of the RMS field strength over six minutes for comparison with the ICNIRP limits, assuming that the activity will take at least six minutes (Joseph et al, 2013, p. 33).

198. As such, the time averaged (RMS) level for a “realistic worst case” exposure scenario can be calculated as:

$$E_{\max \text{ mean duty cycle}}^{RMS} = \sqrt{D_{\max \text{ mean}}} \times E_{\text{beacon meas}}^{\max \text{ hold}}$$

Where

$D_{\max \text{ mean}} = 0.8741$ for the highest average duty cycle of 87.41%

and

$E_{\text{beacon meas}}^{\max \text{ hold}}$ is the max hold level measured for the beacon signal

8.10 WiMax and Broadband Wireless Access (BWA)

199. This sub-section deals with the measurement of emissions from wireless broadband base stations, in particular those operating under WiMAX and similar standards. WiMAX (Worldwide Interoperability for Microwave Access) is a technology based on the IEEE 802.16 set of standards, which is commonly used for the provision of last mile broadband wireless access (BWA). With suitable adjustment of measurement parameters, the measurement techniques outlined here may also be applicable to other similar OFDMA based broadband wireless access technologies (e.g. manufacturer-specific and ‘pre-WiMAX’ systems).

200. WiMAX transmission involves Orthogonal Frequency Division Multiplexing (OFDM) or its variant Orthogonal Frequency Division Multiple Access (OFDMA), whereby signals are composed of multiple narrowband subcarriers equally spread across the full signal bandwidth in the frequency domain (Figure 29). Each subcarrier can be modulated individually with data symbols using BPSK, QPSK, 16-QAM or 64-QAM depending on RF link conditions.

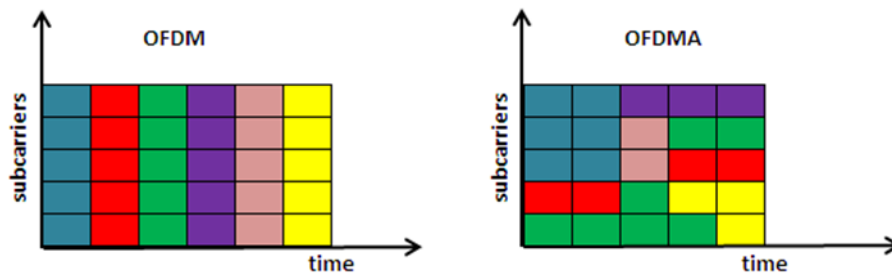

Subcarriers of same colour represent subchannels/users.

Figure 29 -Basic principles of OFDM and OFDMA³⁵

201. As the number of subcarriers used in the frequency domain can vary, WiMAX signals can occupy several transmission bandwidths scalable in the range 1.25 to 28 MHz (Table 29).

Channel Bandwidth Range	1.25 to 28 MHz (usually multiples of 1.25 MHz)				
Typical Channel Bandwidths	1.25 MHz	2.5 MHz	5 MHz	10 MHz	20 MHz

Table 29 - WiMAX channel bandwidths

³⁵ OFDM allocates users (or subchannels) in the time domain only, while OFDMA allocates users in both the time and frequency domains.

202. WiMAX allows for two duplexing techniques: Frequency Division Duplexing (FDD) and Time Division Duplexing (TDD). In FDD systems uplink and downlink transmissions occur on separate frequency channels while uplink and downlink transmissions share the same frequency but are scheduled in different time slots in TDD. TDD tends to be the preferred duplexing mode in WiMAX systems.
203. In the time domain data is transmitted in frames and each frame in the downlink transmission begins with a preamble of either one or two symbols in length. The rest of the frame consists mainly of data symbols. As such, a downlink transmission may consist of only always-on preamble symbols spaced every frame if no data is transmitted.
204. FDD uses fixed duration frames for both uplink and downlink transmissions (Figure 30) while TDD frames consist of a downlink (DL) subframe followed by an uplink (UL) subframe, corresponding to separate downlink and uplink transmission periods (Figure 31).

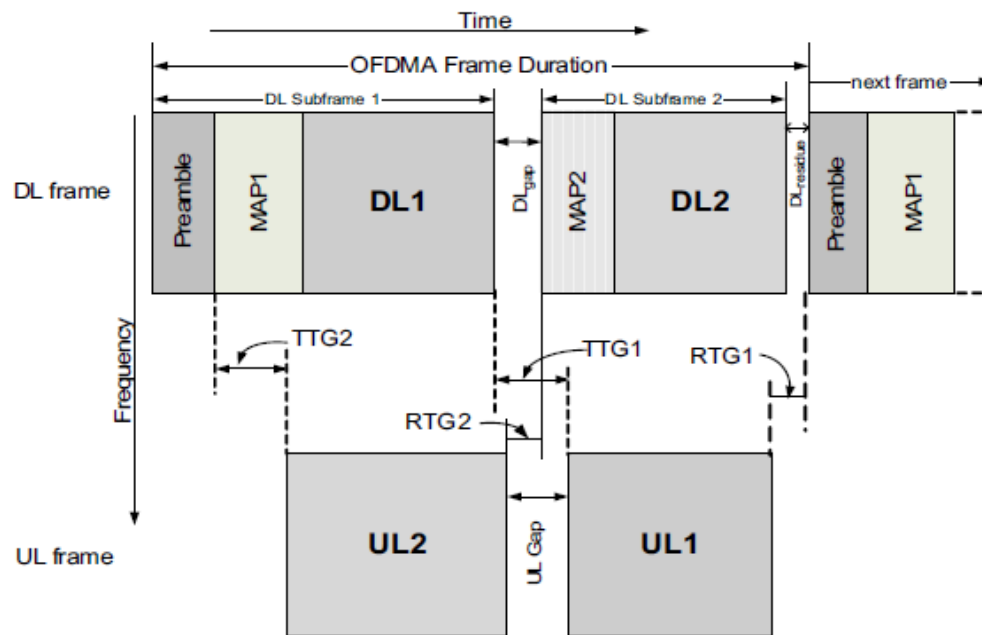

Figure 30 - Generic IEEE 802.16 OFDMA FDD frame structure³⁶

³⁶ Source: IEEE Std. 802.16-2012, p. 898

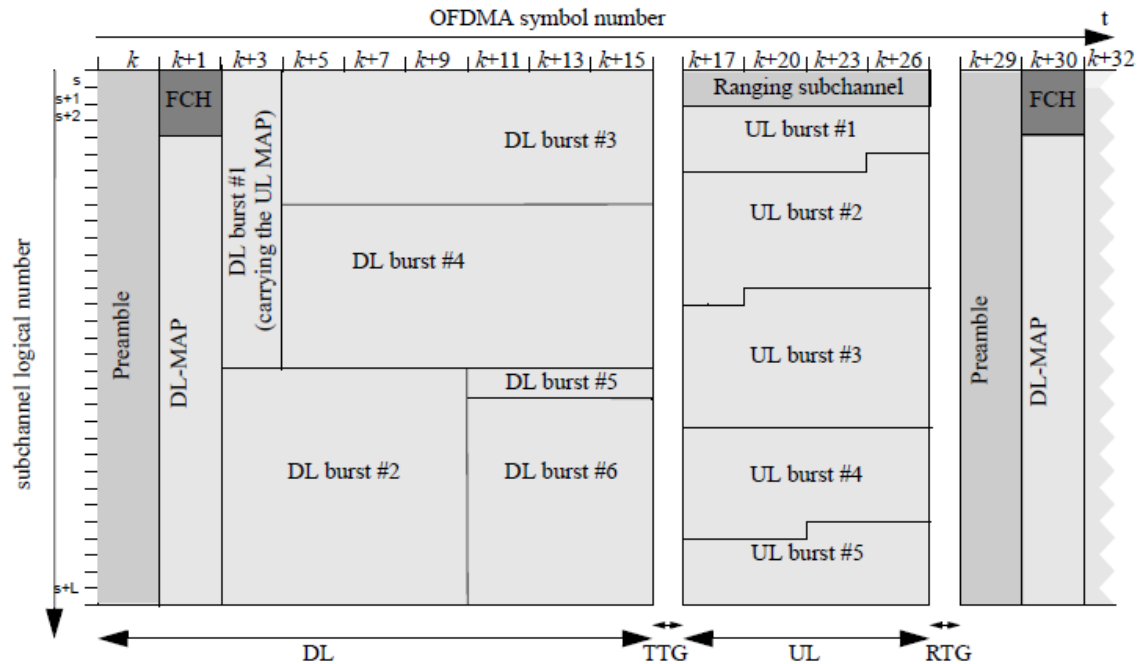

Figure 31 - Example of IEEE 802.16 OFDMA frame in TDD mode³⁷

205. In TDD, downlink subframes can vary up to a maximum duration. TDD framing is adaptive in that the ratio downlink/uplink subframe duration can be adjusted to maximise the efficiency of asymmetric downlink/uplink traffic. In FDD mode it is possible for a base station to transmit a continuous signal if there is a full data load on the downlink. However, in TDD, even at full data load, the base station will transmit for a percentage of the time, corresponding to the maximum downlink subframe duration.

206. The duration of a frame is set by the base station and can range between 2 and 20ms (Table 30) as specified in the IEEE 802.16 standards. However, initially all WiMAX equipment only supported 5ms frame durations.

³⁷ Source: IEEE Std. 802.16-2012, p. 897

OFDM		OFDMA	
Code	Frame duration (ms)	Code(N)	Frame duration (ms)
0	2.5	1	2
1	4	2	2.5
2	5	3	4
3	8	4	5
4	10	5	8
5	12.5	6	10
6	20	7	12.5
		8	20

Table 30 - Possible WiMax frame duration

207. Two procedures for measuring WiMAX emissions, time and frequency domain, are detailed below. Both methods are based on the recommendations for measuring WiMAX emissions outlined in Bornkessel et al (2009, pp. 14 – 27). Time domain measurement gives more accurate results and, as such, is recommended for situations where WiMAX signals are likely to be strong i.e. near a WiMAX base station. In other situations where, for example, numerous low power WiMAX signals from distant base stations are detectable, measuring each signal individually in the time domain can be very time consuming. Instead it may be more practical to conduct measurements in the frequency domain by means of sweeps of each WiMAX band with a spectrum analyser, so that several signals can be measured at the same time.

Time Domain Measurement Method

208. The measurement approach, including parameters to be used on the spectrum analyser, is summarised in Table 30 and explained in further detail below.

Trace Mode	Max Hold
Detector	RMS
RBW	<ul style="list-style-type: none"> • Sufficient to cover signal bandwidth or • Narrower than signal bandwidth if RBW correction factor is applied as per Appendix 3. (For analysers with available RBWs narrower than signal bandwidth)
VBW	3 × RBW
Sweep Time	Ideally equal to signal frame duration
Measurement Duration	A sufficient number of sweeps to display stable signal levels on the analyser screen
Measurement Mode	Time Domain (Zero Span)
Extrapolation for Max Traffic Load	<p>FDD signals No extrapolation required</p> <p>TDD signals</p> $E_{TDD \text{ max duty cycle}}^{RMS} = \sqrt{t_{\text{downlink subframe}}/T_{\text{frame}}} \times E_{\text{meas rms}}^{\text{max hold}}$

Table 31 - WiMAX time domain measurement method

209. With this method, each WiMAX signal detectable must be measured separately in the time domain. The basic approach is to measure the RMS level of the preamble or of data traffic (if present) and to extrapolate that level to the RMS level for the maximum duty cycle of each downlink signal.

210. Measurement is performed on Max Hold with the analyser set to the centre frequency of each WiMAX signal present at the measurement point. RMS detector is used, as the OFDM modulated signals from WiMAX base stations have a high peak to average ratio (approx. 10 dB).

211. A sweep time should be selected such that ideally the elapsed time of a single WiMAX frame (or failing that a small number of frames) is discernible on the analyser display. For example, a sweep time of 5ms is recommended for measuring signals with frames of 5ms duration.
212. It may be the case that the level of the preamble is slightly higher than the rest of the signal if the preamble is transmitted at higher power. Thus, to give an indicative reading, ideally the measured level should be read from time interval reserved for data transmission to subscriber units if data is being transmitted
213. For FDD signals the measured maximum RMS level corresponds to the maximum possible RMS level for the full duty cycle. For TDD signals the maximum possible duty cycle on the downlink is not 100% and corresponds rather to the maximum possible duration of the downlink subframe as a proportion of total TDD frame duration. Thus, the E-field RMS level for a TDD downlink at maximum data traffic can be calculated as:

$$E_{TDD \text{ max duty cycle}}^{RMS} = \sqrt{t_{\text{downlink subframe}}/T_{\text{frame}}} \times E_{\text{meas rms}}^{\text{max hold}}$$

Where

$t_{\text{downlink subframe}}$ = the duration of the downlink subframe

T_{frame} = the duration of the full TDD frame

$E_{\text{meas rms}}^{\text{max hold}}$ is the RMS level measured on the max hold, including any correction for limited RBW.

214. The ratio $t_{\text{downlink subframe}}/T_{\text{frame}}$ may be available from the network operator or it may be possible to determine by inspection in the time domain. If the ratio is not possible to determine, or if it is unclear if the signal is TDD or FDD, then the RMS level measured on max hold should be taken as the measurement and it should be noted in the measurement report that it was not possible to determine the ratio to extrapolate to the maximum duty cycle for the TDD signal and that the level reported may represent an overestimation of the RMS level for the maximum duty cycle. However, if aggregate emissions are found to exceed the Reference Levels, a determination of the RMS level for the TDD downlink signal at its maximum possible duty cycle is necessary for an accurate and justifiable measurement.

215. The time domain measurement approach may be illustrated by way of example. An example time domain measurement of a WiMAX TDD signal is shown in (Figure 32). The measurement is of a TDD frame of 5 ms duration in which the downlink subframe has a maximum duration of 3 ms. In the trace the low level in the final 2 ms of the frame corresponds to the uplink subframe.

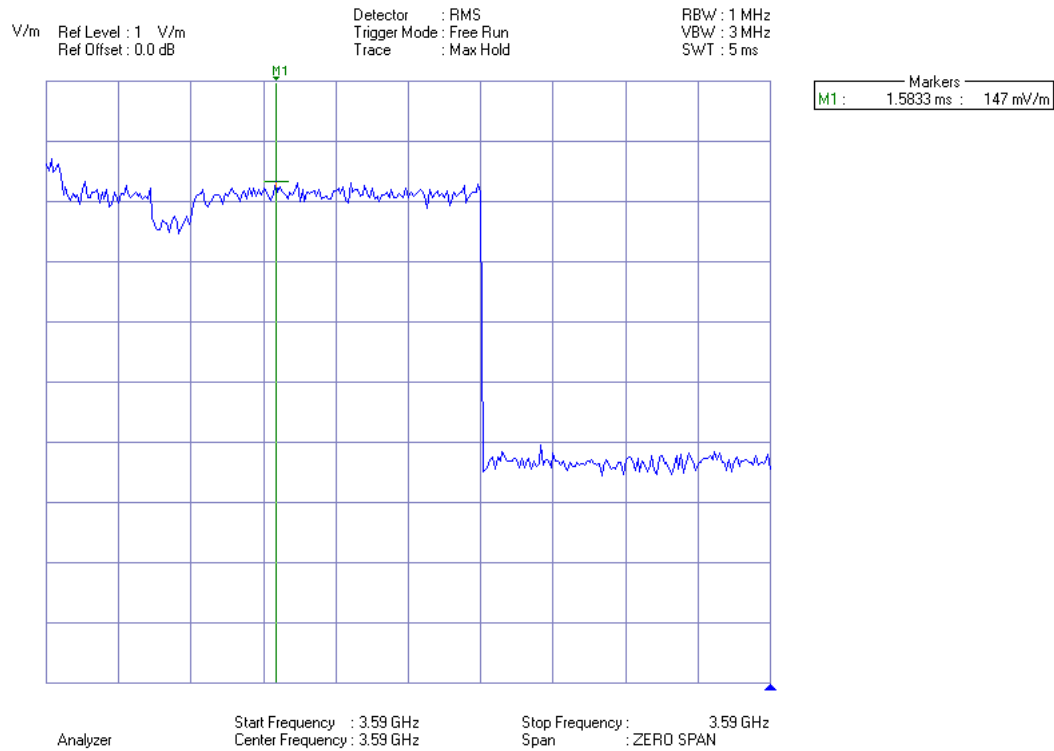

Figure 32 - Example trace of time domain measurement of WiMAX TDD Signal

216. It can be seen at the beginning of the frame that the preamble is at a higher level than the rest of the downlink subframe. Thus, the level is read from the ‘plateau’ corresponding to downlink data transmission as 147 mV/m, as shown by the marker. As the measurement is performed on a 10 MHz wide signal using an RBW of 1 MHz, an RBW correction factor must be applied:

$$K_{RBW} = \sqrt{10 / (1.1 \times 1)} = 3.02$$

For a 5 ms frame with a downlink subframe of 3 ms, the correction factor to apply for extrapolation to the maximum possible TDD signal duty cycle is:

$$\sqrt{t_{\text{downlink subframe}} / T_{\text{frame}}} = \sqrt{3 / 5} = 0.77$$

If the level of 0.147 V/m has been measured with a directional antenna on a vertical polarisation and a separate level of 0.152 V/m has been measured for the signal on a horizontal polarisation, then, correcting for the RBW and the duty cycle:

$$E_{TDD \text{ max duty cycle}}^{RMS} = \sqrt{0.147^2 + 0.152^2} \times 3.02 \times 0.77 = 0.4939 \text{ V/m}$$

Emission Type	Freq. (MHz)	Measured E-Field		Adjusted E-Field				
		VPOL (V/m)	HPol (V/m)	RBW Correction Factor	Est. Max Traffic Extrapolation Factor	Est. Max Traffic Level (V/m)	ICNIRP LIMIT (V/m)	Times below Limit
WiMAX	3590	0.14700	0.15200	3.02	0.77	0.4939	61.0	124

Table 32 - Example tabulation of WiMAX TDD measurement results

Frequency Domain Measurement Method

217. The measurement approach, including parameters to be used on the spectrum analyser, is summarised in Table 32 and explained in further detail below.

Trace Mode	Max Hold
Detector	RMS
RBW	<ul style="list-style-type: none"> • Sufficient to cover signal bandwidth or • Narrower than signal bandwidth if RBW correction factor is applied as per Appendix 3. (For analysers with available RBWs narrower than signal bandwidth)
VBW	3 × RBW
Sweep Time	No of horizontal trace pixels on analyser display × X where X is slightly shorter than downlink preamble duration Indicative value for X = 100 μs
Measurement Duration	A sufficient number of sweeps to display unfragmented signals at stable levels
Measurement Mode	Frequency domain
Extrapolation for Max Traffic Load	<p>FDD signals No extrapolation required</p> <p>TDD signals</p> $E_{TDD \text{ max duty cycle}}^{RMS} = \sqrt{t_{\text{downlink subframe}}/T_{\text{frame}}} \times E_{\text{meas rms}}^{\text{max hold}}$

Table 33 - WiMAX frequency domain measurement method

218. At the time of measurement, it may be the case that the base station is not relaying data, in which case only the preamble is being transmitted in each downlink frame. As the spectrum analyser sweeps across the band it will dwell for a fixed time on each frequency represented by pixels on the horizontal axis of the display. If the dwell time on a pixel is shorter than the interval between each preamble it may not detect a WiMAX signal present on the relevant frequency, as the downlink will consist mainly of gaps with no signal present between each successive preamble. As such, the signal may appear fragmented on the analyser screen and it can take some time for a full spectrum of the signal to become apparent if no preambles are detectable during a pixel dwell (Figure 33). As a single sweep will most likely not show the complete spectrum, measurement requires a sufficient number of sweeps on Max Hold until the signal spectrum is fully represented on the analyser display and the signals are stable at their maximum RMS level.



Figure 33 - Fragmented single after single sweep (left). Coherent signal after multiple sweeps (right)

219. In order to ensure that the RMS level for constant data transmission is not under-calculated due to samples from the gaps between preambles being included when no data is being transmitted, it is necessary to ensure that the dwell time on each horizontal analyser display pixel is shorter than the duration of the always-on preamble. At the same time the pixel dwell time must be long enough to collect as many samples as possible for the RMS calculation. As such, an optimum pixel dwell time will be slightly shorter than the preamble duration. To ensure the required pixel dwell time, the sweep time must be set to a value equal to the number of horizontal trace pixels on analyser display multiplied by a duration which is slightly shorter than the preamble duration.

220. The preamble duration in use on a particular base station downlink may have to be acquired from the network operator. Alternatively, it may be possible to determine it by observing downlink frames in the time domain with a spectrum analyser. In any case preamble durations of 100.8 μs and 102.86 μs is indicative for fixed and mobile WiMAX respectively. In such cases, 100 μs should be a suitable pixel dwell time.

221. For FDD signals the measured maximum RMS value corresponds to the maximum possible RMS for the full duty cycle. For TDD signals the maximum possible duty cycle on the downlink is not 100% and corresponds rather to the maximum possible duration of the downlink subframe as a proportion of total TDD frame duration. Thus, the E-field RMS level for a TDD downlink at maximum data traffic can be calculated as:

$$E_{TDD \text{ max duty cycle}}^{RMS} = \sqrt{t_{\text{downlink subframe}}/T_{\text{frame}}} \times E_{\text{meas rms}}^{\text{max hold}}$$

Where

$t_{\text{downlink subframe}}$ = the duration of the downlink subframe

T_{frame} = the duration of the full TDD frame

$E_{\text{meas rms}}^{\text{max hold}}$ is the RMS level measured on max hold, including any correction for limited RBW.

222. The ratio $t_{\text{downlink subframe}}/T_{\text{frame}}$ may be available from the network operator or it may be possible to determine by inspection in the time domain. If the ratio is not possible to determine, or if it is unclear if the signal is TDD or FDD, then the RMS level measured on max hold should be taken as the measurement and it should be noted in the measurement report that it was not possible to determine the ratio to extrapolate to the maximum duty cycle for the TDD signal and that the level reported may represent an overestimation of the RMS level for the maximum duty cycle. However, if aggregate emissions are found to exceed the Reference Levels, a determination of the RMS level for the TDD downlink signal at its maximum possible duty cycle is necessary for an accurate and justifiable measurement.

8.11 Radar

223. Radar uses radio or microwaves to determine the position, altitude, direction, or speed of objects. Applications of radar include the monitoring of air traffic, marine radar, weather radar to monitor rainfall and anti-collision automotive radar. This section outlines recommendations for measuring pulsed radar signals with a note on the measurement of continuous wave radar signals included at the end.
224. Radar systems detect objects by sending out a rapid succession of short pulses or a continuous high frequency electromagnetic wave and 'listening' for any echoes of the pulses or waves sent back from any obstacle or object encountered in the environment. The pulses are usually short compared to the interval between them. By rotating the antenna, the radar can build up a picture of objects as they are located in the environment. Radar signals tend to be highly directional with a narrow beam and if the antenna rotates, the target is only illuminated for a brief moment.
225. Due to the potentially wide bandwidths of pulsed signals, the measurement procedures outlined here for pulsed radars require spectrum analysers capable of wide resolution bandwidths (e.g. 10 MHz). The analysers must also be capable of very short sweep times (microsecond and possibly nanosecond range) to display pulse waveforms, as well as very long sweep times in the time domain (at least 6 minutes) for RMS measurements. As such, portable analysers may not be suitable.

Pulsed Signal Characteristics

226. Radar pulses are typically of millisecond or nanosecond duration (pulse width). Quite a long-time delay (pulse period) exists between successive pulses³⁸ in order to allow the return echo to be received by the radar before transmission of the next pulse.

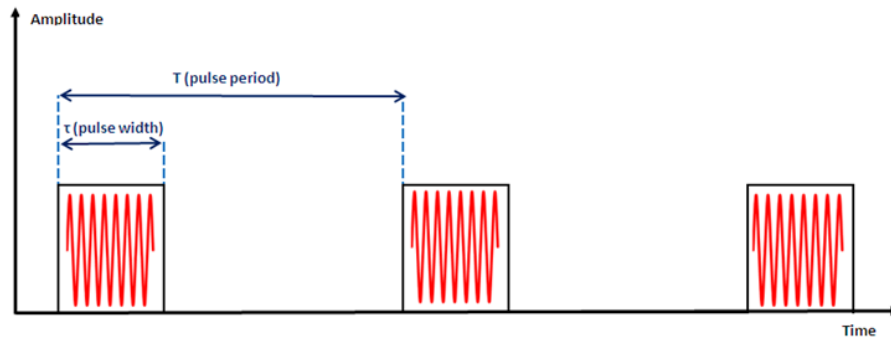

Figure 34 - pulses in the time domain

227. The periodic switching on and off of the pulses gives rise to numerous spectral lines across a wide frequency range – in theory across the whole spectrum. The energy of the periodic pulse occurs in spectral lines at discrete frequencies separated every $1/T$ Hz where T is the pulse period in seconds. The spectral lines form 'lobe' patterns with each lobe spaced out every $1/\tau$ Hz from the centre frequency where τ is the pulse width in seconds (Figure 35). The lobes decrease in amplitude the further they are from the centre frequency.

³⁸ E.g. A primary surveillance radar for air traffic control might use a short pulse width of $1 \mu\text{s}$ and a pulse period of $1000 \mu\text{s}$.

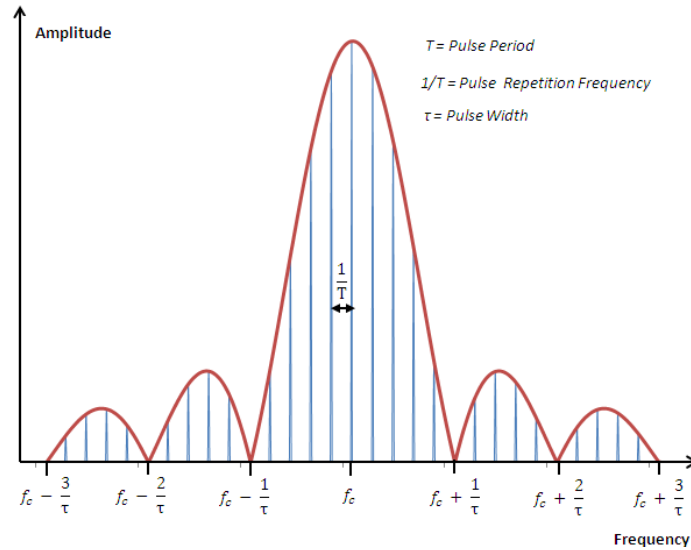

Figure 35 - Spectrum representation of a pulse

Peak Level Measurement

228. This measurement is conducted in the time domain e.g. with the spectrum analyser set to zero span. With the centre frequency set to that of the radar signal, the spectrum analyser is set to sweep on max hold with peak detector for several rotations of the radar antenna until the signal level stabilises. Ideally the sweep time should be set low enough to display a single pulse, with a trigger set to stabilise the pulse trace on screen. The peak value can be read from a marker set to peak within the trace on the analyser screen³⁹. An RBW should be chosen which is sufficient to cover the bandwidth of the pulsed signal (see note on RBW and VBW settings below).

³⁹ Some analysers may have a time domain analysis mode which displays only a level rather than a full trace of the waveform. With such analysers, using max hold and peak detector, the peak level can be read once the display level stabilises after several antenna rotations.

229. It may be the case that there are pulses from multiple radars on different frequencies at a site (e.g. from primary and secondary air traffic radars) or from the same radar on several frequencies if frequency diversity is in use. If the pulses on different frequencies do not occur at the same time, they can be assessed separately as there is no cumulative effect, as may be the case if the pulses from primary and secondary radar at a site are synchronised such that secondary radar pulses leave the antenna before a primary radar pulse. However, if pulses from multiple radars are not synchronised such that it is possible that there is a simultaneous effect due to all pulses occurring at the same time, then the quotients for measured level/limit value (normalised to power density) for each separate radar signal must be summed to determine if the summed value is under 100% (Wuschek, 2013, p.10). This accounts for the worst case of all pulses occurring simultaneously.

RMS Level Measurement

230. In theory it is possible to derive an RMS level from the measured peak level by factoring in the duty cycle of the pulsed signal, the portion of time the measurement point is illuminated by the beam and by making assumptions about the contribution of antenna side and back lobes when the measurement point is not directly illuminated by the beam.

231. However, when measuring modern radars with varying pulse periods and widths, in unpredictable patterns, extrapolating to an RMS level from the measured peak level becomes difficult. For example, an air traffic radar might use short pulses for high discrimination at short ranges and long pulses for long range detection, while secondary surveillance radar for air traffic control uses variable pulse spacing to represent different interrogation modes to aircraft⁴⁰. As such, a direct RMS measurement over numerous antenna rotations will give a more accurate picture considering such variation and will automatically factor in field strength levels resulting from antenna side and back lobes when the measurement point is not directly illuminated by the beam.

⁴⁰ As well as detecting aircraft position, secondary surveillance radar can also send queries to aircraft on its transmit frequency (1030 MHz) for additional information. Transponders on the aircraft reply to these interrogations with encoded data on a separate return frequency (1090 MHz). Interrogation Mode A (identity) uses 8 µs pulse spacing while Mode C (altitude) uses 21 µs pulse spacing. In addition, Mode S for selective interrogation of aircraft uses long phase-modulated pulses of variable length (17.5 – 31.5 µs).

232. Thus, the basic approach is to measure the RMS of emissions from the radar over a six-minute period. Levels are recorded over a single sweep in the time domain (zero span), such that each horizontal trace pixel on the spectrum analyser display records the RMS values for a sub-interval of the total sweep time⁴¹. The analyser must be set to the centre frequency of the signal.
233. For example, if the analyser display has a resolution of 501 horizontal pixels, and measurement is over 6 minutes (360 seconds), then each pixel will record the RMS level for each succeeding $360/501 = 0.72$ second interval. Once the sweep is complete the levels recorded in each pixel can then be used to calculate an RMS level for the full sweep or measurement period.
234. Care should be taken to set the analyser to conduct only a single sweep so that there is no risk of data points being overwritten if a new sweep commences. The sweep is conducted with the analyser on Max Hold with the detector set to RMS. An RBW should be chosen which is sufficient to cover the bandwidth of the pulsed signal (see note on RBW and VBW settings below). A spectrum analyser capable of long sweep times (i.e. 6 minutes or more) is required to perform this type of measurement.
235. Once the sweep is completed, the measurement trace is saved on the analyser. A copy of the trace can then be transferred to a PC. Using the PC software tools provided by the spectrum analyser manufacturer, it should be possible to export the data points representing the levels recorded against each horizontal pixel to a spreadsheet. The data points are then used to calculate an RMS level for the full measurement period using the data points collected over the sweep according to:

$$E_{RMS} = \sqrt{\frac{1}{n} \sum_{i=1}^n E_i^2}$$

236. Where n is the number of samples in the sweep trace and E_i represents the RMS level recorded in each sample.

⁴¹ If the analyser has a time domain analysis mode which displays only a level rather than a full trace of the pulse waveform, it may have the facility to measure and display a running RMS level over time. With such analysers, using average hold (if the averaging algorithm is RMS) and RMS detector, the RMS level can be read from the display after the required measurement period.

237. If a radar being measured uses frequency diversity, whereby the signal may hop between frequencies in different time intervals or different pulse widths are used on different frequencies, separate RMS measurements must be performed on each frequency.

RBW and VBW Settings

238. In respect of both peak and RMS measurements of pulsed radar signals, careful consideration needs to be given to the selection of an appropriate RBW. In theory the energy of pulse modulated signals is spread across the whole spectrum. However, according to ECC Recommendation (02)04 (p. 15) a measurement filter width of $4/\tau$, where τ is the pulse width, should make it possible to obtain 99% of the power of the signal. Thus, a suitable resolution bandwidth for measuring a pulsed signal may be calculated as:

$$RBW_{(Hz)} = \frac{4}{\tau_{(seconds)}}$$

239. When measuring radars with transmit pulses of variable length, the RBW must be selected on the basis of the smallest possible pulse width which will determine the maximum bandwidth of the signal.
240. Based on the above formula, measurement of a 1 μ s pulse will require an RBW of at least 4 MHz. For narrower pulse widths suitably wide RBWs may not be available on spectrum analysers. For example, a surface movement radar with a pulse width of 40 ns will theoretically require an RBW of at least 100 MHz. In such cases where RBWs available on a spectrum analyser are insufficient or it is difficult to get an RBW equal to the bandwidth of the pulsed signal, lower RBWs can be used to conduct separate zero span measurements of segments of the bandwidth of the pulsed signal. A cumulative calculation is then carried out to derive the level across the full pulsed signal bandwidth. As the highest proportion of the signal energy will be distributed around the centre frequency, one of the measurements must be on the centre frequency, so that frequency response of the IF filter (Gaussian) is optimised on the centre frequency.
241. For example if a surface movement radar transmits 40 ns pulses (with a 100 MHz bandwidth) on a centre frequency of 16 GHz and the maximum RBW available on a spectrum analyser is 10 MHz, then 11 individual measurements with an RBW of 10 MHz can be conducted on spot frequencies every 10 MHz between 15,950 and 16,050 MHz, including on the radar centre frequency of 16,000 MHz.

242. In order to derive a field strength for the full signal, the measured levels on each spot frequency across the signal bandwidth are then summed according to:

$$E_{total} = \sqrt{\sum_{i=1}^n E_i^2}$$

The VBW should be set to a value greater than or equal to the RBW.

Antenna Orientation

243. For both peak and RMS measurement, three separate measurements must be performed with the antenna oriented in each of three orthogonal directions to obtain the different components of the field. The total field may be calculated as:

$$E_{total} = \sqrt{E_x^2 + E_y^2 + E_z^2} \quad \text{or} \quad H_{total} = \sqrt{H_x^2 + H_y^2 + H_z^2}$$

244. If a three-axis (“isotropic”) antenna is used, a single isotropic measurement is not appropriate. A three-axis measurement system repeatedly measures field strength on each axis in turn and a cycle through all three axes can last over 100 ms. However, as the beam from rotating radars typically only illuminates the target for a much shorter interval (e.g. 22 ms for a radar with 2° beam width and 4 second rotation) the scan time is too long to assess adequately the resulting field across all three axes (Eskerski & Braach, 2007, p. 3). Thus, with three-axis antennas three separate measurements must be performed, one on each axis. An “isotropic result” is then calculated from the levels measured on each axis as per the above formula.

Weather Radars – Special Considerations

245. Weather radars perform a scan of the sky involving 360° horizontal rotations of the antenna at incremental elevations to compile a 3-dimensional volume picture of weather systems. A single volume scan can take about 5 to 10 minutes.

246. As the antenna elevation changes, the field strength level at a measurement point will also change. As the radar progresses through its volume scan sequence the field strength will most likely be at its highest at a measurement point on the ground when the antenna is at its lowest elevations and at its lowest when the antenna is at its maximum elevation. As such, a peak measurement must be performed over at least the full duration of a volume scan as it will not be clear which antenna elevation will illuminate the measurement point at the highest field strength and in any case the antenna elevation may not be clear if the antenna is behind a radome.
247. In cases where the volume scan duration exceeds the required measurement period, an RMS measurement (i.e. single sweep on zero span) must be conducted over the full volume scan duration. In order to assess worst case exposure, the 6-minute window of RMS level data points from the zero-span measurement which yield the maximum RMS level calculation should be used. An RMS measurement averaged over the first 6 minutes of a volume scan when the antenna elevation is lowest will most likely be greater than an RMS level averaged over the final 6 minutes when the antenna is at higher elevations.
248. It may be the case that an RMS measurement commences during rather than at the beginning of a volume scan. As such, the first six minutes of the measurement may not be representative of the first six minutes of the volume scan or when the field strength is at its highest. To mitigate this problem, a duplicate of the measurement data points should be appended to volume scan data points in a spreadsheet. This allows a full volume scan sequence to be reconstructed.
249. The approach is best illustrated by way of example. If the volume scan of a weather radar lasts 8 minutes and the antenna elevation changes every two minutes in sequence from minimum to maximum, the field strength at the measurement point will be at its highest levels during the first 6 minutes (Figure 36).

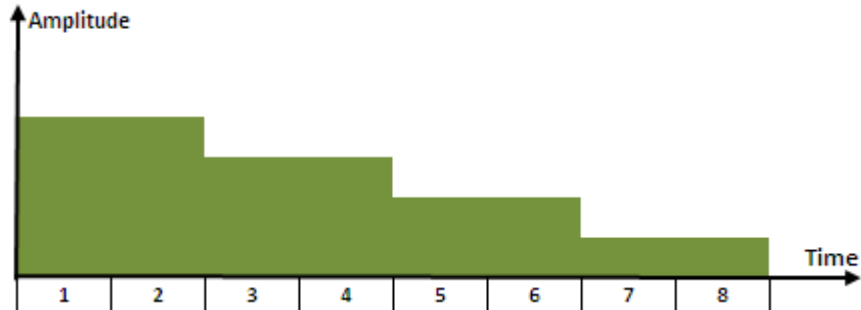

Figure 36 - Volume scan - in sequence start to end (8 mins)

250. However, if the measurement commences during the fourth minute of a volume scan, the field strength will be at its median level at the measurement point (Figure 37).

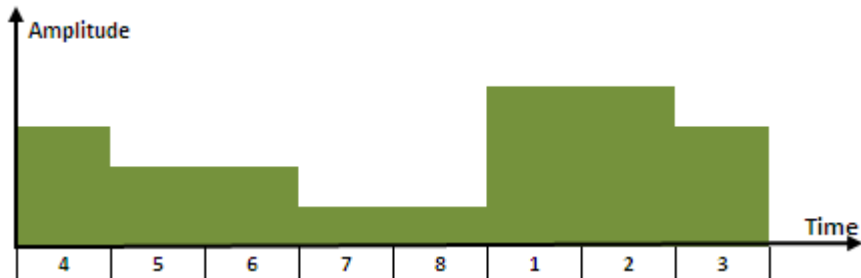

Figure 37 - Measurement Window

251. Furthermore, using any 6-minute window within the 8 minute measurement to calculate the RMS will lead to an underestimation of the worst case which lies between minutes 1 to 6 of the volume scan, which are separated at opposite ends of the measurement window in Figure 37. By duplicating and appending the measurement data points, the picture of a full volume scan sequence can be reconstructed (Figure 38). This gives a sequence of changing field strength levels due to variation in antenna elevation from which a maximum RMS value over 6 minutes can be calculated.

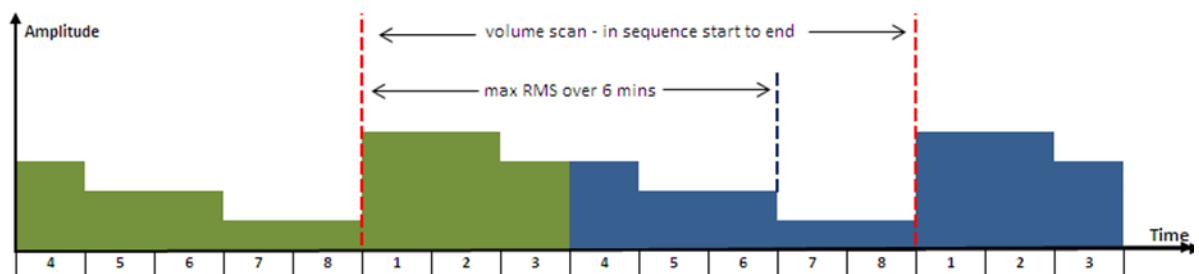

Figure 38 - Volume scan measurement window duplicated

252. A time domain analysis mode, available on some spectrum analysers, which displays only a running RMS level over time, is not suitable for this measurement approach, as a full trace of the sweep over the measurement duration is required for later analysis.

Measurements on Continuous Wave Radars

253. Some types of radar emit continuous waves rather than pulses. These types of radar are used to detect movement rather than range and examples include automatic door detectors, proximity sensors, vehicle speed gauges and traffic light radars.
254. As the signal is continuous and there are no considerations for antenna rotation and pulse duty cycles, emissions from these radars can be measured in the frequency domain. A sweep over the required measurement period with a spectrum analyser on max hold with detector set to RMS will suffice. An RBW should be used which covers the signal bandwidth. However, if the RBWs available on the analyser are insufficient, a correction factor can be applied to the measured level as per Appendix 3. The VBW should be set at least three times the RBW. A sweep time of at least 100 ms will be sufficient to sample variations in the continuous waveform oscillating in the MHz and GHz ranges.

8.12 Noise

255. During site surveys electromagnetic noise emissions may sometimes be encountered in several bands. Such noise may be attributable to spurious emissions from sources such as nearby emitters and electrical machinery.
256. Where such noise is appreciable⁴², it is important to measure and record the levels, as the field strength of the noise may contribute significantly to the aggregate electromagnetic field. As such, any noise levels measured must be factored into the calculations of the Total Exposure Quotients.

⁴² 'Appreciable' should be taken to mean less than 40 dB below the relevant Reference Level for a particular frequency at which noise occurs. For E-Field measurements, this corresponds to a factor of 100 times below the Reference Level.

Frequency Selective Measurement Procedure

- (1) If signals are present in the band to be measured, then the noise must be measured in a separate analyser band scan to the signals. The parameters to be used on the spectrum analyser are shown in Table 34.

Trace Mode	Max Hold
Detector	RMS
RBW	100 kHz
VBW	300 kHz
Sweep Time	100 ms
Measurement Duration	6 minutes
Measurement Mode	Frequency domain

Table 34 - Noise measurement parameters

257. Continue according to the standard procedure for Measurement with Isotropic Antennas (in the frequency range 75 MHz to 3 GHz) or Measurement with Directional Antennas (below 75 MHz and above 3 GHz) as appropriate.

Measurement Analysis Procedure

- (1) Sample the noise levels every x MHz throughout the frequency selective scan (where x is the RBW). Any signals present in the band should be excluded from the sampling and treated separately.
- (2) The total E-field level for noise in the band may then be calculated from each sample (E_{noise_i}) as follows:

$$E_{noise\ band} = \sqrt{\sum_{i=start\ freq}^{stop\ freq} (E_{noise_i})^2}$$

- (3) The quotient⁴³ for noise in the band should be calculated from the level (E_{noise_i}) measured at each sampling point in the scan and from the relevant Reference Level for the frequency. (Note that Reference Levels may vary across the band as they are frequency dependent.)
- (4) The quotient calculated must be added to the Total Exposure Quotient calculated for the signals.

Reporting Measurement Results

Emission Type	Frequency Band (MHz)	ICNIRP LIMIT (V/m)	Measured Level (V/m)	Times Below Limits	Quotient for noise in the band
Noise	1900-1920	59.9-60.2 (varying by frequency)	0.1951868	308	0.0000105

Table 35 - Example table of E-Field levels for noise measured in the 1900-1920 MHz

⁴³ See Appendix 2 for calculation of quotients. The quotient for the band is to be calculated in the same manner as the Total Exposure Quotient.

8.13 Other Signals – General Measurement Principles

258. It may be that an unexpected or new signal type occurs in a frequency band, which does not fall into any of the categories (PMR, GSM, LTE etc.) for which measurement techniques have been specified elsewhere in this section. For such signal types published measurement standards or recommendations may be available from competent bodies such as CENELEC⁴⁴, the German Federal Office for Radiation Protection (BfS)⁴⁵ or the Swiss Federal Office of Metrology (METAS)⁴⁶. If any such standards or recommendations are used to measure new or unexpected signal types, they should be fully referenced in the measurement report.
259. If relevant measurement standards or recommendations are not available from competent bodies, it is recommended to use the general principles outlined in this sub-section to derive suitable spectrum analyser parameters for the measurement of such signals based on their characteristics. Details of signal characteristics should be available in the relevant technical standards (from ETSI, IEEE etc.). Any approach applied using these principles should be documented and justified in the measurement report, e.g. why they were suited to the characteristics of the signal measured. When applying these principles, it may be useful to refer to the measurement techniques previously specified previously in this section for signal types such as PMR, GSM, LTE, etc.
260. The general principles for determining spectrum analyser parameters are as follows:

Trace Mode

261. The spectrum analyser should be set to sweep on Max Hold in order that the highest possible signal levels are captured. These levels may represent worst case exposure due to technologies with variable transmission power.

⁴⁴ www.cenelec.eu

⁴⁵ <http://www.bfs.de>

⁴⁶ <http://www.metas.ch/>

Detector

262. RMS detector is recommended as a general rule as the ICNIRP Guidelines specify reference levels in terms of unperturbed RMS values. In addition, RMS detector is best suited to measuring many types of digitally modulated signals which exhibit high crest factors (or peak-to-average ratios).
263. However, peak detector may be more suitable for some complex signals where a full train of pulses, frames, sub-frames or symbols, corresponding to a maximum exposure or data traffic scenario, might not occur at the time of measurement (like GSM). In such cases an RMS detector might under-calculate a maximum possible RMS level by using samples from time intervals when the signal might not be in the 'on' state e.g. in time slots where not data happens to be available for multiplexing at the time.

Resolution Bandwidth (RBW)

264. Typically, the RBW should be sufficient to cover the signal bandwidth. For spectrum analysers with available RBWs narrower than the signal bandwidth it is possible to use an RBW narrower than signal bandwidth if an RBW correction factor is applied as per Appendix 3.
265. Some signals may consist of multiple sub-carriers across the full signal bandwidth (e.g. OFDM type signals like LTE) but where only a narrow subset of the subcarriers are constantly transmitted for signalling / synchronisation purposes, with other subcarriers transmitted only when needed to transmit call/data traffic. In such cases it may be appropriate to extrapolate from a measurement with a suitably narrow RBW to cover the bandwidth of portion of the signal bandwidth which includes the always-on signalling / synchronisation subcarriers and to extrapolate the measurement to the full signal bandwidth using and RBW correction factor as per Appendix to derive a level indicative of maximum data/call traffic.

Video Bandwidth (VBW)

266. When using the RMS detector, too low a VBW can cause the analyser to display measurement values which are too low. To avoid this problem the VBW should be set at a value at least three times the RBW with the RMS detector (Rauscher et al, 2008, p. 70). With peak detector the VBW should be greater than or equal to the RBW.

Sweep Time

267. For simple constant power signals, a sweep time of at least 100 ms should be used in order for the detector to gather sufficient samples. More complex signals may consist of a train of pulses, frames, sub-frames or symbols in succeeding time slots. In such signals it may be the case that transmission only occurs in the time slots when there is data available to relay or that only beacon/synchronisation frames etc are constantly transmitted in certain time slots. For these signals it may be more appropriate to set a sweep time such that the dwell time on each horizontal pixel of the spectrum analyser display closely matches the duration of the pulses, frames, sub-frames or symbols so that sufficient samples of the signal in the 'on' state are gathered by the detector for calculation of an RMS value.

Measurement Duration

268. Typically, a sufficient number of sweeps must be conducted to display stable levels on the spectrum analyser. For intermittent signals which occur in very short bursts (like PMR) it is more appropriate to sweep for a longer duration (6 minutes) in order to capture as many of those signals as possible that are detectable at the measurement point.

Extrapolation of Measured Levels

269. With signals from some technologies the measured level might not be representative of the system transmitting at maximum call or data traffic load. For example, transmission power might increase with traffic load (e.g. W-CDMA) or the system might vary the number carriers depending on load (like GSM) but only one carrier is detectable at the time of measurement

270. In such cases it may be appropriate to apply a multiplicative factor, representing the maximum possible number of carriers or the ratio of maximum to minimum possible transmission power, to the measured level to extrapolate to a level indicative of the maximum number of carriers or transmission power. For other signals, which do not transmit continuously even at maximum data traffic, it may be appropriate to apply a correction factor to the measured level, representing the maximum duty cycle or proportion of time signal is in 'on' state, in order to provide a more indicative RMS level. For the E-field the extrapolated level for the maximum traffic load or duty cycle of the signal may be calculated as:

$$E_{max} = E_{meas} \times K_{corr}$$

Where E_{meas} is the measured level and the correction factor $K_{corr} = \sqrt{X}$

271. with X representing the maximum number of carriers, the ratio (max/min transmission power) or duty cycle, as applicable.

Measurement Mode

272. Some signals may consist of regularly transmitted signal elements (preambles, synchronisation channels, beacon frames etc.) and are only in the 'on' state in the intervals between those elements when there is data to relay. If frequency domain pixel dwell times available on the spectrum analyser are much longer than the signal element duration, the RMS level might be under-calculated due to inclusion of too many samples of the signal in the 'off' state (e.g. from the intervals between succeeding beacon frames if no data is being transmitted. In addition, if data transmission does not occur at the time of measurement the always-on signal elements might be difficult to capture as they may be missed by the detector during a pixel dwell which is of shorter duration than the interval between the always-on elements. For such signals, a time domain (zero span) measurement is recommended.

9 Appendices

Section	Page
Appendix: 1 ICNIRP Reference Levels – General Public Exposure.....	116
Appendix: 2 Total Exposure Quotients	118
Appendix: 3 Correcting for Spectrum Analyser RBW Limitations	120
Appendix: 4 References.....	121

Appendix: 1 ICNIRP Reference Levels – General Public Exposure

A 1.1 ICNIRP has defined basic restrictions and reference levels. Depending on frequency, the physical quantities used to specify the basic restrictions on exposure to electromagnetic fields (EMF) are specific energy absorption rate, absorbed power density, specific energy absorption, absorbed energy density, induced (internal) electric field strength. These quantities are not easily measurable in living people therefore reference levels have been obtained from the basic restrictions by mathematical modelling and by extrapolation from the results of laboratory investigations at specific frequencies.

A 1.2 The reference levels are provided for comparison with measured values of physical quantities; compliance with all reference levels given in these guidelines will ensure compliance with basic restrictions. If measured values are higher than reference levels, it does not necessarily follow that the basic restrictions have been exceeded, but a more detailed analysis is necessary to assess compliance with the basic restrictions. ICNIRP 2010 provides reference levels (Table 34) relating to electrical stimulation effects at low frequencies. ICNIRP 2020 provides reference levels (Table 36) relating to whole body exposure, averaged over 30 min, to electromagnetic fields from 100kHz to 300GHz.

Frequency range	E-field strength E (kV m ⁻¹)	Magnetic field strength H (A m ⁻¹)	Magnetic flux density B (T)
1 Hz–8 Hz	5	$3.2 \times 10^4/f^2$	$4 \times 10^{-2}/f^2$
8 Hz–25 Hz	5	$4 \times 10^3/f$	$5 \times 10^{-3}/f$
25 Hz–50 Hz	5	1.6×10^2	2×10^{-4}
50 Hz–400 Hz	$2.5 \times 10^2/f$	1.6×10^2	2×10^{-4}
400 Hz–3 kHz	$2.5 \times 10^2/f$	$6.4 \times 10^4/f$	$8 \times 10^{-2}/f$
3 kHz–10 MHz	8.3×10^{-2}	21	2.7×10^{-5}

Notes:

- f in Hz.

- See separate sections below for advice on non sinusoidal and multiple frequency exposure.

- In the frequency range above 100 kHz, RF specific reference levels need to be considered additionally.

Figure 39 - ICNIRP 2010 Reference levels for general public exposure to time-varying electric and magnetic fields (unperturbed rms values)⁴⁷

⁴⁷ Source: ICNIRP 2010, p. 827

Exposure scenario	Frequency range	Incident E-field strength; E_{inc} ($V\ m^{-1}$)	Incident H-field strength; H_{inc} ($A\ m^{-1}$)	Incident power density; S_{inc} ($W\ m^{-2}$)
Occupational	0.1 – 30 MHz	$660/f_M^{0.7}$	$4.9/f_M$	NA
	>30 – 400 MHz	61	0.16	10
	>400 – 2000 MHz	$3/f_M^{0.5}$	$0.008/f_M^{0.5}$	$f_M/40$
General public	>2 – 300 GHz	NA	NA	50
	0.1 – 30 MHz	$300/f_M^{0.7}$	$2.2/f_M$	NA
	>30 – 400 MHz	27.7	0.073	2
	>400 – 2000 MHz	$1.375/f_M^{0.5}$	$0.0037/f_M^{0.5}$	$f_M/200$
	>2 – 300 GHz	NA	NA	10

^aNote:

1. "NA" signifies "not applicable" and does not need to be taken into account when determining compliance.
2. f_M is frequency in MHz.
3. S_{inc} , E_{inc} , and H_{inc} are to be averaged over 30 min, over the whole-body space. Temporal and spatial averaging of each of E_{inc} and H_{inc} must be conducted by averaging over the relevant square values (see eqn 8 in Appendix A for details).
4. For frequencies of 100 kHz to 30 MHz, regardless of the far-field/near-field zone distinctions, compliance is demonstrated if neither E_{inc} or H_{inc} exceeds the above reference level values.
5. For frequencies of >30 MHz to 2 GHz: (a) within the far-field zone: compliance is demonstrated if either S_{inc} , E_{inc} or H_{inc} , does not exceed the above reference level values (only one is required); S_{eq} may be substituted for S_{inc} ; (b) within the radiative near-field zone, compliance is demonstrated if either S_{inc} , or both E_{inc} and H_{inc} , does not exceed the above reference level values; and (c) within the reactive near-field zone: compliance is demonstrated if both E_{inc} and H_{inc} do not exceed the above reference level values; S_{inc} cannot be used to demonstrate compliance, and so basic restrictions must be assessed.
6. For frequencies of >2 GHz to 300 GHz: (a) within the far-field zone: compliance is demonstrated if S_{inc} does not exceed the above reference level values; S_{eq} may be substituted for S_{inc} ; (b) within the radiative near-field zone, compliance is demonstrated if S_{inc} does not exceed the above reference level values; and (c) within the reactive near-field zone, reference levels cannot be used to determine compliance, and so basic restrictions must be assessed.

Figure 40 - ICNIRP 2020 Reference levels for whole body exposure, averaged over 30-min to electromagnetic fields from 100 kHz 300 GHz (unperturbed rms values)⁴⁸

A 1.3 ICNIRP 2020 also provides basic restrictions and reference levels relating to local exposure (i.e. of head, torso and limbs) which are set much higher than the basic restrictions and reference levels for whole-body exposure. The measurement of local exposure, as opposed to whole-body exposure, is not relevant in the context of the site surveys addressed by this methodology. In any case, given that the ICNIRP 2020 reference levels for local exposure are set much higher than those for whole-body exposure, measurements conducted in accordance with this methodology which comply with the ICNIRP 2020 reference levels for whole-body exposure will, by default, also comply with the ICNIRP 2020 reference levels for local exposure. Further information on local exposure basic restrictions and reference levels can be found in ICNIRP 2020.

⁴⁸ Source: ICNIRP 2020, p. 13

Appendix: 2 Total Exposure Quotients

A 2.1 ICNIRP has specified a means of assessing additivity of exposures in situations of simultaneous exposure to fields of different frequencies. Additivity is examined separately for the effects of electrical and thermal stimulation, and ICNIRP has set out basic restrictions which should be met for both considerations.

A 2.2 For practical application of the basic restrictions, ICNIRP has advised that the following criteria⁴⁹ regarding reference levels of field strengths should be applied:

Induced Current Density and Electrical Stimulation:

A 2.3 As per ICNIRP 2010 (p. 829) For induced current density and electrical stimulation effects, relevant up to 10 MHz, the following two requirements should be applied to the field levels:

$$\sum_{j=1 \text{ Hz}}^{10 \text{ MHz}} \frac{E_j}{E_{R,j}} \leq 1$$

And

$$\sum_{j=1 \text{ Hz}}^{10 \text{ MHz}} \frac{H_j}{H_{R,j}} \leq 1$$

where

E_j = the electric field strength at frequency j ;

$E_{R,j}$ = the relevant electric field reference level as per ICNIRP 2010;

H_j = the magnetic field strength at frequency j ;

$H_{R,j}$ = the relevant magnetic field reference level as per ICNIRP 2010.

⁴⁹ Here referred to as Total Exposure Quotients

Thermal Considerations

A 2.4 For thermal considerations, relevant above 100 kHz, ICNIRP 2020 sets out formulae for assessing the additivity of exposure across multiple frequencies. The additivity of whole-body exposure across multiple frequencies is assessed according to:

$$\sum_{i=100 \text{ kHz}}^{30 \text{ MHz}} \left\{ \left(\frac{E_{inc,i}}{E_{inc,RL,i}} \right)^2 + \left(\frac{H_{inc,i}}{H_{inc,RL,i}} \right)^2 \right\}$$

$$+ \sum_{i>6 \text{ GHz}}^{2 \text{ GHz}} \left\{ \left(\frac{E_{inc,i}}{E_{inc,RL,i}} \right)^2 + \left(\frac{H_{inc,i}}{H_{inc,RL,i}} \right)^2 + \left(\frac{S_{inc,i}}{S_{inc,RL,i}} \right) \right\}$$

$$+ \sum_{i>2 \text{ GHz}}^{300 \text{ GHz}} \left(\frac{S_{inc,i}}{S_{inc,RL,i}} \right) \leq 1$$

$E_{inc,i}$ and $E_{inc,RL,i}$ = are the whole-body average incident electric field strength and whole-body average incident electric field strength reference level given as per ICNIRP 2020 at frequency i , respectively.

$E_{inc,i}(t)$ = is the whole-body average E_{inc} level over time t .

$H_{inc,i}$ and $H_{inc,RL,i}$ = are the whole-body average incident magnetic field strength and whole-body average incident magnetic field strength reference level given as per ICNIRP 2020 at frequency i , respectively.

$H_{inc,i}(t)$ = is the whole-body average H_{inc} level over time t .

$S_{inc,i}$ and $S_{inc,RL,i}$ = and the whole-body average incident power density and whole-body average incident power density strength reference level given as per ICNIRP 2020 at frequency i , respectively.

$S_{inc,i}(t)$ = is the whole-body average $S_{inc,i}$ level over time t .

Appendix: 3 Correcting for Spectrum Analyser RBW Limitations

A 3.1 Where possible, the spectrum analyser should be set to a resolution bandwidth (RBW) sufficiently large to cover the bandwidth of the emission being measured. However, in the case of wideband emissions (e.g. DVB-T, WIFI, WiMAX etc.) it may not be possible to set the spectrum analyser to an RBW equal to the bandwidth of the emission. For example, a spectrum analyser with a maximum possible RBW of 5 MHz cannot directly measure a DVB-T signal across its full 7.61 MHz bandwidth.

A 3.2 In such cases it is necessary to compensate for the limited RBW of the spectrum analyser by applying an RBW Correction Factor to the measured emission level in order to calculate an adjusted level which accounts for all the energy present within the full bandwidth⁵⁰ of the emission.

A 3.3 The RBW correction factor is to be derived as follows:

$$K_{RBW} = \sqrt{B_{Signal}/B_N}$$

Where B_{Signal} = signal or emission bandwidth

B_N = noise bandwidth of the analyser filter

(for a Gaussian Filter: $B_N \approx 1.1 \times B_{3dB}$)

Example: Measuring a 7.61 MHz DVB-T signal with 5 MHz RBW:

$$B_{Signal} = 7.61 \text{ MHz}$$

$$B_{3dB} = \text{RBW} = 5 \text{ MHz} \quad \Rightarrow \quad B_N = 1.1 \times 5 = 5.5$$

$$\therefore K_{RBW} = \sqrt{7.61/5.5} = 1.18$$

⁵⁰ In rare instances it may be apparent that the actual bandwidth of a signal exceeds its regular stated bandwidth, e.g. due to inadequate filtering at the transmitter end. In such cases the RBW correction factor should take into account the actual bandwidth of the signal.

Appendix: 4 References

- A 4.1 Bienkowski P. and Trzaska H. (2012), Electromagnetic Measurements in the Near Field, 2nd Edition, Raleigh NC, USA, Scitech Publishing Inc.
- A 4.2 Bornkessel C. (2011), 'Messung der Elektromagnetischen Immissionen von LTE-Basisstationen (Measuring electromagnetic emissions from LTE base stations)', EMF Spectrum, 1/2011, pp. 10-15,
- A 4.3 <http://www.wik-emf.org/fileadmin/EMF-Spectrum/WIK-EMF-Spectrum-2011-1.pdf>
- A 4.4 Bornkessel C. (2013), 'Immission measurements in the vicinity of LTE base stations - Part 1: Principles', Narda Safety Test Solutions Application Note,
- A 4.5 http://www.narda-sts.de/pdf/fachartikel/AN_HF_1062_E_LTE_Principles_2013-04-22.pdf
- A 4.6 Bornkessel C., Schubert M., Wuschek M. (2009), 'Bestimmung der Exposition durch WiMAX : Band 2: Entwicklung geeigneter Verfahren (Determining WiMAX exposure: Volume 2: Development of a suitable technique)' prepared for the German Federal Office for Radiation Protection by Institut für Mobil- und Satellitenfunktechnik (IMST), Kamp-Lintfort and EM-Institut, Regensburg, http://doris.bfs.de/jspui/bitstream/urn:nbn:de:0221-2009042328/1/BfS_2009_BfS-RESFOR-10-09-Bd2.pdf
- A 4.7 Bornkessel C., Schubert M. and Wuschek M. (2012), 'Bestimmung der Exposition der allgemeinen Bevölkerung durch neue Mobilfunktechniken: Zwischenbericht (Determining general public exposure to emissions resulting from new mobile technologies: Interim report)', prepared for the German Federal Office for Radiation Protection,
- A 4.8 http://www.emf-forschungsprogramm.de/akt_emf_forschung.html/dosi_HF_004_ZwB_01.pdf
- A 4.9 ECC REC (02)04 (revised Bratislava 2003, Helsinki 2007), "MEASURING NON-IONISING ELECTROMAGNETIC RADIATION (9 kHz – 300 GHz)", published by the European Communications Committee on www.ero.dk
- A 4.10 IEEE Std. 802.16-2012, IEEE Standard for Air Interface for Broadband Wireless Access Systems, New York, 2012

- A 4.11 EN 50492:2008/A1:2014, 'Basic standard for the in-situ measurement of electromagnetic field strength related to human exposure in the vicinity of base stations', Brussels, CENELEC, November 2008, as amended March 2014
- A 4.12 Eskerski C. and Braach B., 2007, 'Application Note: Radar measurements with the Selective Radiation Meter SRM-3000 using air traffic control radar as an example', Narda Safety Test Solutions GmbH, Pfullingen, Germany,
- A 4.13 http://www.narda-sts.de/pdf/fachartikel/AN_HF_1003_E_Radarmessungen_2007-07-24.pdf
- A 4.14 ETSI TS 136 211 V13.3.0 (2016-11), LTE; Evolved Universal Terrestrial Radio Access (E-UTRA); Physical channels and modulation (3GPP TS 36.211 version 13.3.0 Release 13)
- A 4.15 Joseph W., Pareit D., Vermeeren G., Naudts D., Verloock L., Martens L. and Moerman I. (2013), 'Determination of the duty cycle of WLAN for realistic radio frequency electromagnetic field exposure assessment', Progress in Biophysics and Molecular Biology, 111(1), pp. 30-36
- A 4.16 Rauscher C., Janssen V. and Minihold R. (2008), Fundamentals of Spectrum Analysis, Munich, Rohde & Schwarz GmbH
- A 4.17 Wuschek M. (2012), 'Messung hochfrequenter Felder in der Umgebung von Funksendeanlagen: Erfahrungen aus der Praxis. Teil 1: Messverfahren und Methoden (Measurement of high frequency fields in the vicinity of wireless transmitter sites: Lessons from practice. Part 1: Measurement principles and methods)', EMF Spectrum, 2/2012, pp. 28-31,
- A 4.18 <http://www.wik-emf.org/fileadmin/EMF-Spectrum/WIK-EMF-Spectrum-2-2012lowres.pdf>
- A 4.19 Wuschek M. (2013), 'Expositionsmessungen bei Rundsuchradaranlagen zur Luftverkehrskontrolle (Exposure measurements on rotating search radar for air traffic control)', Deggendorf Institute of Technology, https://www.th-deg.de/files/0/fakultaet_et-mt/Messleitfaden_Radar.pdf