



An Coimisiún um
Rialáil Cumarsáide
Commission for
Communications Regulation

Mobile Handset Performance (Data)

Reference: ComReg 18/82

Date: 19/09/2018

Content

Section	Page
1 INTRODUCTION 5
1.1 BACKGROUND	6
The Mobile Phone and Broadband Taskforce	6
The Commission for Communications Regulation (ComReg)	7
1.2 FACTORS AFFECTING MOBILE USER EXPERIENCE	8
Radio frequency spectrum and antennas.....	8
1.3 METRICS TO MEASURE MOBILE HANDSET PERFORMANCE	11
Industry-recommended minimum values for TIS.....	11
2 TIS MEASUREMENT METHODOLOGY & RESULTS	.. 13
2.1 OVERVIEW OF TIS TEST METHODOLOGY	13
Mobile Frequency Bands and Technologies tested.....	14
Mobile Handsets	15
TIS Measurement Methodology	15
2.2 MEASUREMENT RESULTS.....	17
TIS Measurements for HR Scenario	17
TIS Measurements for HL Scenario	20
2.3 SUMMARY.....	22

Annex

Section	Page
Annex: 1 Mobile Handsets Tested	24
Annex: 2 Standards and Measurement Techniques	26
Annex: 3 Test Setup and Equipment	33
List of Abbreviations	35

Table of Figures

Section	Page
Table 1: GSMA Operator Acceptance Values for TIS	12
Table 2: Mobile Technologies and Channel Frequencies Tested	14
Table 3: TIS (dBm) for the HR scenario in the LTE-800 band in decreasing order	17
Table 4: TIS (dBm) for the HL scenario in the LTE - 800 band in decreasing order	20
Table 5: Maximum diameter of HUT	32
Table 6: System specifications	32
Table 7: OTA performance measurement specifications	32
Table 8: Measurement Equipment	33

Chapter 1

1 INTRODUCTION

- 1.1 The Commission for Communications Regulation (ComReg), in its Radio Spectrum Management Strategy Statement for 2017 to 2018¹, outlined a number of issues which it believed contribute to mobile user experience. It further stated that it would endeavour to develop a greater understanding of the issues affecting mobile coverage, seek solutions to deliver improved outcomes, and support the Government's proposed Task Force on Rural Mobile Coverage and Broadband.
- 1.2 Several factors will affect the quality of the mobile service that a user will experience, at any given location. Those factors include local terrain (mountains, hills, valleys and foliage); the density of the mobile network (the number of base stations and the user's distance from the connecting base station); the spectrum bands being utilised by different technologies (2G (GSM), 3G (UMTS), 4G (LTE), etc) and the propagation characteristics of those bands (i.e. the ability of radio waves to travel over distance and to penetrate buildings and other physical obstacles); and the number of people using mobile handsets at the same time and location.
- 1.3 Two other key factors affect mobile user experience. The first is the make and model of mobile handset being used and the second is the effect of building materials on indoor coverage. As part of its initiative to better understand and objectively measure the factors that affect mobile coverage, and as aligned with recommendations of the Mobile Phone and Broadband Taskforce, ComReg decided to further examine these two factors. This has resulted in the publication of three technical reports, of which this is the third.
- 1.4 ComReg first tested the *voice call* performance of 71 mobile handsets that were available on the Irish market in June 2017. ComReg measured the Total Radiated Power (TRP) of each handset which is a measurement of a mobile handset's transmit performance for voice calls and its antenna radiation patterns. On 6 February 2018, ComReg published its technical report (Doc 18/05)² which sets out the transmit performance results of the 71 mobile handsets.
- 1.5 On 2 August 2018, ComReg published a second technical report (Doc 18/73)³ which set out the results of its measurements of the effect of *building materials* on indoor mobile performance. The report explained that some modern building materials – especially those containing metals such as foil-backed thermal insulation or windows with aluminium or metallic frames - can have a significant

¹<https://www.comreg.ie/publication/radio-spectrum-management-strategy-statement-2016-2018-design/>

² https://www.comreg.ie/?dln_download=mobile-handset-performance-voice

³ <https://www.comreg.ie/publication/the-effect-of-building-materials-on-indoor-mobile-performance/>

impact on radio signals as they penetrate a building. The foil or metal layers help reduce heat loss from inside but also 'reflect' incoming radio signals from outside, thereby effectively shielding the inside of the building from mobile signals outside.

- 1.6 ComReg is now publishing this third technical report. On this occasion, ComReg measured the Total Isotropic Sensitivity (TIS) of the same 71⁴ mobile handsets available on the Irish market in June 2017, and that were previously measured for TRP. TIS is a measure of the receive performance *for data*⁵ and the antenna sensitivity patterns of mobile handsets.
- 1.7 ComReg will continue to measure the performance of all new makes and models of mobile handsets that become available on the Irish market, on a regular and ongoing basis, for voice and data, and those measurements will also be published as they become available.

1.1 BACKGROUND

The Mobile Phone and Broadband Taskforce

- 1.8 The Department for Communications, Climate Action and Environment, pending roll-out of the National Broadband Plan (NBP), has implemented a number of initiatives to enhance the quality of mobile phone and data services across Ireland and particularly in rural Ireland. One such initiative, taken in line with the current Programme for Government, was the establishment of the Mobile Phone and Broadband Taskforce in July 2016.
- 1.9 The Taskforce, in a report published in December 2016⁶, stated that its remit is "to examine solutions to address broadband/mobile phone coverage deficits and to identify tangible actions that can be taken to improve the quality of broadband and mobile voice services being provided to citizens across Ireland."
- 1.10 The Taskforce also observed in the same report that the telecommunications sector underpins Ireland's transition to a digital economy and there is a clear need to reinforce, develop and expand telecommunications networks on an ongoing basis. Furthermore, and to do so effectively, would require the input and cooperation of a broad range of public and private actors.
- 1.11 The Taskforce, in pursuit of the above objectives, set out 40 recommendations⁷ and/or actions to alleviate barriers to mobile reception and broadband access, to

⁴ Some of the 71 mobile handsets that support voice functionality do not have data functionality.

⁵ As outlined in ComReg Action Plan - https://www.comreg.ie/media/2016/05/Annual-Action-Plan-Year-300618_Updated.pdf.

⁶ <https://www.chg.gov.ie/app/uploads/2016/12/taskforce-report.pdf>

⁷ The most recent progress report on the implementation of the recommendations can be found at - <https://www.dccae.gov.ie/documents/Mobile%20Phone%20and%20Broadband%20Taskforce%20Q2%20Progress%20Report.pdf>

be delivered by a range of bodies including Government Departments, State agencies, ComReg and industry providers. With regard specifically to Consumer Issues, among others, the following actions were allocated to ComReg:

28. ComReg will carry out regular testing to determine the sensitivity of mobile phone handsets on the market. The results will be updated at regular intervals. Industry should consider making this information available at point of sale.

29. A composite national coverage map will be generated from comprehensive data, including data provided by operators and made available by ComReg on its consumer website.

The Commission for Communications Regulation (ComReg)

1.12 ComReg is the national regulatory authority for the electronic communications sector in Ireland which includes managing the radio frequency spectrum, a national resource. ComReg's core statutory objectives are to promote competition, to contribute to the development of the internal market, to promote the interests of users of electronic communications services (including users of mobile voice and data services), and to ensure the efficient management and use of the radio frequency spectrum.⁸

1.13 ComReg, in its Radio Spectrum Management Strategy Statement for the period 2017 to 2018 ("Radio Spectrum Strategy") published in June 2016, stated that it would "*endeavour to get a greater understanding of the coverage issues and to seek solutions which can deliver improved outcomes and to support the proposed Government's Task Force on both rural mobile coverage and broadband.*"⁹ Subsequently, and as mentioned above, in December 2016 the Mobile Phone and Broadband Task Force¹⁰ recommended that ComReg should carry out regular testing to determine the sensitivity of mobile phone handsets on the Irish market.¹¹ This was also reiterated in ComReg's proposed Strategy Statement for the period 2019 to 2021¹².

⁸ Annex 2 of ComReg Doc 17/85 sets out a more detailed synopsis of ComReg's statutory functions, objectives, and powers in managing radio spectrum.

⁹<https://www.comreg.ie/publication/radio-spectrum-management-strategy-statement-2016-2018-design/>

¹⁰ <https://www.chg.gov.ie/app/uploads/2016/12/taskforce-report.pdf>

¹¹ ComReg has also stated, in its current consultation on its Radio Spectrum Management Strategy Statement for the period 2019 to 2021, that it will continue to facilitate a better understanding of the factors impacting on the actual mobile consumer experience (see section 3.3.10 of Doc 18/74).

¹² See Document 18/74 – Proposed Strategy for Managing the Radio Spectrum – 2019 to 2021 - <https://www.comreg.ie/publication/proposed-strategy-for-managing-the-radio-spectrum-2019-2021/>

1.14 In late 2016, in accordance with its strategic plan and alignment with taskforce actions, ComReg commenced two parallel projects in order to gain greater understanding of two factors that affect mobile user experience:

- (i). **Effect of Building Materials on Indoor Coverage**: To determine the extent to which modern building materials impact on in-building coverage by measuring the penetration loss resulting from a radio wave of known field strength propagating through the building material under test.
- (ii). **Mobile Handset Performance**: To measure the performance of mobile handsets available on the Irish market in order to quantify the minimum signal level(s) required to make or receive a mobile call and to stream data.¹³

1.15 As noted above, ComReg first published the results of its testing of the voice call performance of 71 makes and models of mobile handsets (Doc 18/05). Next, ComReg, published the results of its measurements of the effect of building materials on indoor mobile performance. (Doc 18/73). This third report sets out the results of ComReg's testing of the data performance of the same 71 makes and models of mobile handsets.

1.2 FACTORS AFFECTING MOBILE USER EXPERIENCE

1.16 A number of factors will affect the quality of the mobile service that a user will experience at any given location. Those factors include the density of the mobile network (i.e. the number of base stations and the user's distance from the connecting base station); the spectrum bands being utilised and the propagation characteristics of those bands (i.e. the ability of the transmitted radio waves to travel over distance and to penetrate buildings and other physical obstacles); the number of people using mobile handsets at the same time and location; and the mobile handset itself.

1.17 While most of these factors vary over time and by location, the one factor that is relatively constant, from the mobile user's perspective, is the mobile handset.

Radio frequency spectrum and antennas

1.18 All forms of wireless electronic communications use the same medium – radio spectrum. Every radio wave has a unique frequency (measured in Hertz or Hz) and wavelength (measured in metres) which for free space when multiplied by

¹³ Currently in licences issued by ComReg that contain a coverage condition the performance of an ideal handset is used as the basis of the requirement itself and the method by which compliance is measured. This is derived from EU and ITU standards on receiver performance. See 3GPP TS 36.101

one another always equal the speed of light. Therefore, the higher the frequency the shorter the wavelength, and vice versa. Further, a radio wave with a longer wavelength (lower frequency) can travel further through free space than a radio wave with a shorter wavelength (higher frequency) before the strength of the wave becomes so diminished that it can no longer be received.

- 1.19 These propagation characteristics mean that radio waves in spectrum bands with relatively long wavelengths can travel further than radio waves with shorter wavelengths while still being strong enough to be received. Accordingly, due to their relatively long wavelength, radio waves in lower-frequency spectrum bands are better suited to providing mobile coverage over larger geographic areas and at relatively lower cost, because fewer masts and base stations are required. The mobile communications networks used in Ireland operate in a variety of frequency bands ranging from as low as 800 MHz up to several GHz. The “*sub-1 GHz bands*” are commonly referred to as “*coverage bands*” because of their long-range propagation characteristics.
- 1.20 “*Capacity bands*”, on the other hand, lie in the various frequency bands above 1 GHz. Radio waves in these higher-frequency bands can travel over comparatively shorter distances before the signal becomes too weak to be received. Capacity bands are therefore used in more populous urban and suburban areas, where substantial network capacity is required.
- 1.21 In common with practices elsewhere, Irish mobile network operators (MNOs) utilise a mixture of coverage and capacity bands to provide service to consumers.
- 1.22 The reliance upon multiple spectrum bands means that mobile handsets must contain multiple antennas that are capable of effectively transmitting and receiving signals in those same bands. An antenna is an integral physical component of every mobile handset; indeed, every piece of radio equipment that is capable of transmitting or receiving a wireless signal requires an antenna in order to do so. A transmitting antenna converts an electric current into a radio frequency (RF) electromagnetic field and, at the other end, a receiving antenna intercepts the RF field and converts it back to an electric current. The quality and performance of the antenna will therefore have a fundamental impact on the quality and performance of the radio equipment to which it connects.
- 1.23 Further, just as the propagation characteristics of radio waves change with frequency, the physical characteristics of antennas affect their radio performance. In particular, there is no standard “*one size fits all*” antenna. Instead there is a fundamental relationship between the length of a radio wave and the size of the antenna needed to generate (or, at the opposite end, to intercept) that radio wave. An antenna typically needs to be at least one-tenth the size of the wavelength it receives. Antennas of approximately one half the size of the received wavelength tend to perform best.

- 1.24 The propagation characteristics of radio waves and of the antennas required to generate and detect radio waves must be taken into account in the design and manufacture of mobile handsets. Mobile handsets must contain multiple antennas, with each antenna designed to transmit and receive radio signals in a specific spectrum band and (for the reasons outlined above) the antennas must also be of a certain physical size in order to operate effectively.
- 1.25 Antennas were clearly visible in most first generation (“1G”) and second generation (“2G”) mobile handsets (which could be used for voice calls and later also for texting, but not for data). The antennas in many such handsets either protruded permanently from the top corner or could be extended telescopically. 3G networks capable of providing mobile data services were later rolled out and were followed by the current generation of 4G networks that are capable of providing faster mobile data services. Mobile handset technology has evolved in tandem with network technology and has led to the widespread adoption of 3G and 4G “*smartphones*”.
- 1.26 Smartphones are far more functionally advanced than their 1G and 2G predecessors (commonly referred to as “*feature phones*”¹⁴). Modern smartphones pack ever more computing power, battery capacity, data storage, display area, cameras and other technologies into increasingly thin plastic, glass, or metal cases. Their design and appearance is also an important factor for consumers and is one of the areas in which smartphone manufacturers compete. All of this means that a smartphone’s multiple antennas, which are essential components, must compete with all other system components for the amount of available space within the casing. As a result, antennas in many modern smartphones can be small¹⁵ (relative to their optimum size) and easily obscured.¹⁶
- 1.27 If an antenna within a mobile handset is obscured then that will affect the antenna’s ability to generate and detect the very radio waves that are fundamental to the handset’s performance. This will ultimately affect the experience of the user of the mobile handset in making or receiving voice calls or in downloading or uploading data.
- 1.28 ComReg’s overall objective in this project is to gain a greater understanding of the factors that will affect the experience of users of mobile services, in making or receiving voice calls or in streaming data. ComReg, therefore acquired 71 of

¹⁴ The term “Feature Phones” in this context refers to those low-cost mobile handsets designed solely for voice calling and SMS/text messaging.

¹⁵ For small size antennas, there is always a trade-off among antenna radiation quality factor(Q), BW and efficiency (η) (C. P. Huang, 1999; Dalia Nashaat et al, 2003)

The rule of thumb is: $\frac{BW\eta}{V} = Constant$

Where BW is antenna bandwidth, η is the antenna efficiency and V is the antenna volume. This shows that as volume decreases bandwidth and/or efficiency must also decrease

¹⁶ Radio signals when faced with obstructions in their propagation to the antenna hinders the line of sight from a transmitter tower to the antenna which can have an adverse effect on quality of reception.

the mobile handsets available on the Irish market at the time of the study from various sources on the open market which it measured, in order to replicate the mobile user experience. ComReg measured the transmit and receive performance of each mobile handset as a complete device.

1.3 METRICS TO MEASURE MOBILE HANDSET PERFORMANCE

- 1.29 A mobile handset must connect to the nearest base station in order to access a mobile network. The connection from handset to base station is the “uplink” (handset transmits / base station receives) and the connection from base station to handset is the “downlink” (base station transmits / handset receives). The weaker of these two links will determine the quality of the connection between the mobile handset and the mobile network.
- 1.30 Research indicates¹⁷ that the strength of the uplink tends to determine the limits of coverage for voice calls, while for data, the mobile handset spends most its time on the network consuming data from remote servers which means the downlink is the more critical connection. Two conclusions can thus be drawn:
- (i). A mobile handset’s *transmit performance* (i.e. its ability to generate radio waves) has the greater impact on the quality and consistency of mobile *voice services*.
 - (ii). A mobile handset’s *receive performance* (i.e. its ability to detect radio waves) has the greater impact on the quality and consistency of mobile *data services*.
- 1.31 This report deals exclusively with (ii) above in that it sets out measurements of mobile handset receive performance. Measurements of mobile handset transmit performance (i.e. (i) above) were published in (Doc 18/05).
- 1.32 A mobile handset receive performance is determined by measuring the total isotropic sensitivity received by the antenna over a three-dimensional sphere – this is referred to as the **Total Isotropic Sensitivity** “TIS”.
- 1.33 TIS is a measure of the lowest power level that can be received by the handset while maintaining connection with the base station. The lower the TIS measurements, the better the sensitivity of the handset.

Industry-recommended minimum values for TIS

- 1.34 The Cellular Telephone Industries Association (“CTIA”)¹⁸, an international industry trade group which represents the wireless communications industry

¹⁷ Aalborg University Report Mobile Phone Antenna Performance 2016 (“TIS and TRP Measurements”, pp. 16) - <https://www.pts.se/upload/Rapporter/Tele/2016/MobilephoneTest2016-augusti-2016.pdf>

¹⁸ <https://www.ctia.org/>

including cellular, and the 3rd Generation Partnership Program (“3GPP”)¹⁹ have published standardised procedures for Over-the-Air (OTA) measurement of TIS for mobile handsets. Annex: 2 contains an overview of those standardised measurement procedures.

Using these standardised measurement procedures, 3GPP and the GSM Association (GSMA)²⁰ has also published its recommended minimum TIS values for acceptable mobile handset performance, across the 3G and 4G/LTE bands. Table 1 below sets out the recommended minimum TIS values set by GSMA.

Table 1: GSMA²¹ Operator Acceptance Values for TIS

Technology (3G/4G)		Bands (MHz)	Acceptance Values for TIS (dBm)
			GSMA Browsing
UMTS	Band 1	2100	-103
	Band 8	900	-101
LTE	FDD Band 3	1800	-91
	FDD Band 20	800	-89.5

¹⁹ The 3GPP is a collaboration between groups of telecommunications associations, known as the Organizational Partners. See <http://www.3gpp.org/>

²⁰ The GSM Association (commonly referred to as 'the GSMA') is a trade body that represents the interests of mobile network operators worldwide. See <http://www.gsma.com/>

²¹ <https://www.gsma.com/newsroom/wp-content/uploads/TS-24-v3-01.pdf>

Chapter 2

2 TIS MEASUREMENT METHODOLOGY & RESULTS

- 2.1 This chapter explains how ComReg measured the Total Isotropic Sensitivity (TIS) for the mobile handsets available on the Irish market as of June 2017 and presents the results of those measurements.
- 2.2 All measurements were taken in a controlled radio frequency (“RF”) environment and in accordance with methodologies set by the Cellular Telephone Industries Association (CTIA). In carrying out the measurements, ComReg also took account of previous work in this same area conducted by Aalborg University²² and, separately, by the UK electronic communications regulator, Ofcom.²³ The methodology was also independently reviewed by Queen’s University Belfast.²⁴
- 2.3 As set out by CTIA²⁵ test plan, in order to represent real world usage of mobile handset, an appropriate standard phantom hand shall be employed when testing. In the set of tests conducted by ComReg, various phantom hands were used. The selection of the appropriate phantom hand was based on the width of the mobile handset. A phantom PDA hand²⁶ was used for mobile handsets that have width between 56 mm and 72 mm and UWPDA²⁷ (Ultra-wide PDA) phantom hand was used for mobile handsets having width in the range of 72 mm to 92 mm²⁸. Annex 1 sets out the type of hand used for each mobile handset that was tested. Identical test procedures were used for all handsets.

2.1 OVERVIEW OF TIS TEST METHODOLOGY

- 2.4 A radio-isolated anechoic chamber²⁹ was constructed and tested and a programmable handset measurement system was installed in the chamber along with a simulated mobile network base station and measurement equipment – see Figure 1 and 7. The simulated base station and measurement equipment

²² <https://www.pts.se/upload/Rapporter/Tele/2016/MobilephoneTest2016-augusti-2016.pdf>

²³ https://www.ofcom.org.uk/__data/assets/pdf_file/0015/72231/mobile_handset_testing_1v01.pdf

²⁴ <http://www.ecit.qub.ac.uk/CWI>

²⁵ CTIA version 3.7

²⁶ PDA phantom hand is a type of phantom hand that fits mobile handsets with widths ranging from 56 mm to 72 mm

²⁷ UWPDA phantom hand is an ultra-wide PDA hand capable of holding handsets with widths ranging from 72 mm to 92 mm

²⁸ Differences between requirements for devices wider and narrower than 72 mm reflect observed differences in OTA performance with different hand phantoms of up to **6 dB**. (CTIA version 3.7)

²⁹ An **anechoic chamber** (an-echoic meaning "non-reflective, non-echoing, echo-free") is a room designed to completely absorb reflections of either sound or electromagnetic waves.

transmit and receive signals from the mobile handset. The resulting measurements were used to generate a representation of the handset's sensitivity pattern.



Figure 1: MVG StarLab Measurement System on the right was placed inside the Anechoic Chamber on the left for TRP and TIS Measurement

2.5 Annex: 2 and 3 describe, in greater detail, the measurement methodology and applicable standards and the equipment used. The paragraphs below list the radio frequency bands and mobile handsets which were tested.

Mobile Frequency Bands and Technologies tested

2.6 Table 2 sets out the technologies and downlink channel frequencies currently used in Ireland to operate mobile networks and provide mobile services. The TIS for each mobile handset was measured using the mid-channel frequency only, so as to reduce the total number of measurements, and measurements were done using UMTS and LTE technologies only.

Table 2: Mobile Technologies and Channel Frequencies Tested

Technology		Bands (MHz)	Channel Frequency (MHz)		
			LOW	MID	HIGH
UMTS	Band 1	2100	2112.4	2140	2167.6
	Band 8	900	927.4	942.6	957.6
LTE	Band 3	1800	2115	2140	2165
	Band 20	800	796	806	816

Mobile Handsets

- 2.7 As outlined above, where applicable³⁰, ComReg measured the TIS for the same handsets that were tested for TRP i.e. 71 makes and models of mobile handsets that were available on the Irish market as of June 2017. These included various makes and models of smartphone and feature phone³¹. Full details of the 71 makes and models of handsets are provided in Annex: 3.
- 2.8 ComReg acquired one sample of each handset on the assumption that all mobile handsets are mass-produced to identical specifications and are subject to strict quality control processes. As such, one would not expect there to be any substantial difference between the TIS measurements for two or more new models of the same mobile handset³².

TIS Measurement Methodology

- 2.9 The TIS performance of each mobile handset was measured using two scenarios which simulated the manner in which people typically use their mobile handsets in everyday life – i.e. when browsing. Each mobile handset was positioned in a phantom right hand (see Figure 2)³³. The test was then repeated with the same handset positioned in a phantom left hand. TIS measurements were taken for each of these two scenarios:
- Handset in right hand (“HR”)
 - Handset in left hand (“HL”)

³⁰ Some of the 71 mobile handsets that support voice functionality do not have data functionality

³¹ The term “Feature Phones” in this context refers to those low-cost mobile handsets designed solely for voice calling and SMS/text messaging.

³² ComReg understands and appreciates that mobile handset manufacturers adopt stringent quality control procedures during the manufacturing process, in an effort to minimise the number of defective handsets that reach the open market. ComReg is not privy to the exact percentage rates of defective handsets that do reach the open market and therefore cannot quantify or estimate the number of defective handsets that are purchased by end-users. However, if any manufacturer should have reason to believe that ComReg has acquired and tested a defective or unrepresentative sample of a handset, the manufacturer may inform ComReg of its concerns and ComReg, upon being thus informed, will acquire and test a second sample of the same make and model of handset.

³³ Phantoms hands are used to evaluate the effect of the human body on electromagnetic radiation and are manufactured from high-quality materials which stimulate the tissue and density of human hands and heads.

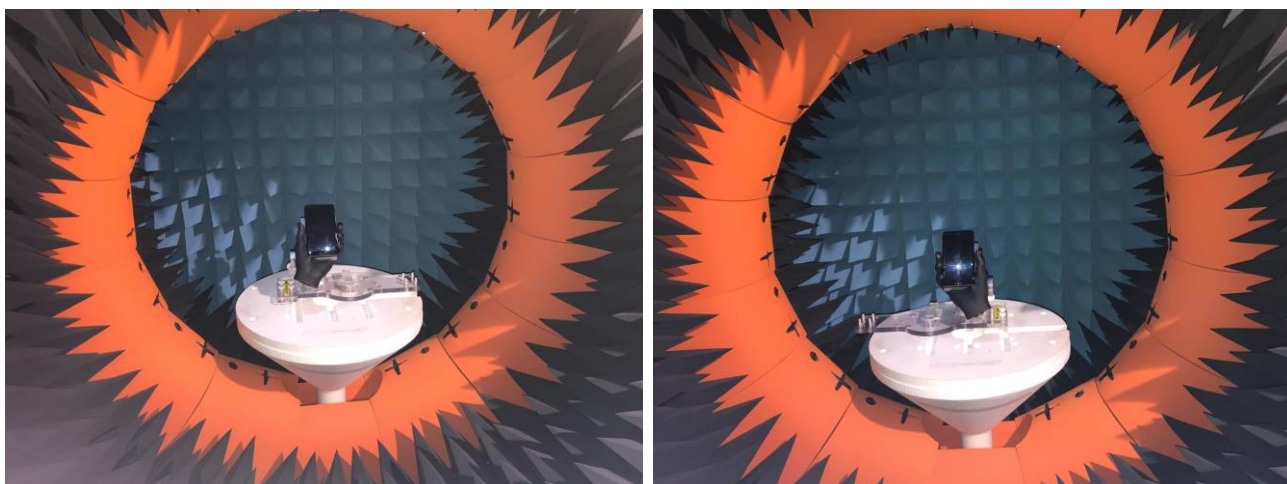

Figure 2: Handset Positioning for HL (left) and HR (right) scenarios

2.2 MEASUREMENT RESULTS

TIS Measurements for HR Scenario

2.10 Table 3 sets out the TIS measurements for the HR scenario (handset held in right hand) for all 71 handsets in the LTE 800³⁴, LTE 1800³⁵, UMTS 900³⁶ and UMTS 2100³⁷ bands where applicable³⁸. The handsets are listed in decreasing order of TIS measurements in the LTE - 800 band.

Table 3: TIS (dBm) for the HR scenario in the LTE-800 band in decreasing order of sensitivity

***F – Feature Phone, *S – Smart Phone**

Mobile Handset	LTE- 800	LTE - 1800	UMTS- 900	UMTS -2100
Huawei P9 Lite (S)	-96.28	-95.37	-108.09	-107.78
Huawei P10 (S)	-95.44	-93.88	-106.95	-108.75
Microsoft Lumia 550 (S)	-95.04	-94.75	-105.56	-106.54
Samsung Galaxy S6 Edge (S)	-94.74	-92.74	-105.87	-105.59
Samsung Galaxy A3 (S)	-93.94	-96.45	-105.79	-107.15
Samsung Galaxy S7 (S)	-93.85	-96.32	-105.85	-106.93
Samsung Galaxy S8 (S)	-93.84	-96.24	-105.51	-107.39
Samsung Galaxy J3 (S)	-93.72	-93.28	-106.17	-107.39
Vodafone Smart Ultra 7 (S)	-93.68	-95.89	-106.7	-102.12
Microsoft Lumia 650 (S)	-93.49	-92.93	-105.92	-105.64
Samsung Galaxy S7 Edge (S)	-93.43	-96.23	-107.2	-107.56
Apple iPhone 7 (S)	-93.34	-93.56	-102.84	-104.49
Huawei Y6 (S)	-93.33	-95.55	-103.33	-106.81
Samsung Galaxy Note5 (S)	-93.12	-94.71	-106.85	-107.66
Samsung Galaxy S6 (S)	-93.08	-94.54	-104.26	-108.36
Apple iPhone 7+ (S)	-93.07	-91.13	-105.77	-103.25
Samsung Galaxy S8+ (S)	-92.88	-96.83	-107.93	-106.9
Huawei Honor 8 (S)	-92.86	-94.93	-105.71	-109.34
HTC Desire 825 (S)	-92.46	-97.8	-106.47	-110.24
Sony Xperia XZ (S)	-92.37	-96.1	-101.92	-108.78
Microsoft Lumia 640 (S)	-92.27	-93.79	-105.63	-106.13
Motorola Moto G(3rd Gen) (S)	-92.17	-93.62	-102.01	-108.11
Sony Xperia M4 (S)	-92.15	-96.76	-102.86	-109.45
Vodafone Smart Turbo 7 (S)	-91.98	-94.53	-102.28	-104.37

³⁴ The “800 MHz band” means the 791 to 821 MHz band paired with the 832 to 862 MHz band as set out in Annex 3 to ComReg Document 12/25

³⁵ The “1800 MHz band” means the 1710 to 1785 MHz band paired with the 1805 to 1880 MHz band as set out in Annex 3 to ComReg Document 12/25

³⁶ The “900 MHz band” means the 880 to 915 MHz band paired with the 925 to 960 MHz band as set out in Annex 3 to ComReg Document 12/25

³⁷ The “2100 MHz band” means the 1920 to 1980 MHz band paired with the 2110 to 2170 MHz band

³⁸ Some of the 71 mobile handsets that may support voice functionality do not have data functionality

Mobile Handset	LTE- 800	LTE - 1800	UMTS- 900	UMTS -2100
Apple iPhone 5s (S)	-91.86	-92.35	-104.38	-103.44
Huawei Honor 8 Pro (S)	-91.68	-92.19	-105.58	-103.69
Microsoft Lumia 950 (S)	-91.61	-95	-102.85	-103.9
Apple iPhone 6s (S)	-91.6	-93.91	-104.14	-107.85
Huawei P9 (S)	-91.55	-92.82	-105.7	-107.02
Huawei Mate S (S)	-91.51	-94.15	-102.98	-105.75
Samsung Galaxy S5 mini (S)	-91.47	-95.23	-98.39	-105.84
HTC Desire 530 (S)	-91.45	-97.8	-105.72	-110.4
Samsung Galaxy J5 (S)	-91.4	-92.48	-105.34	-103.39
Huawei Y5 (S)	-91.3	-96.39	-104.5	-108.36
Apple iPone SE (S)	-91.11	-92	-104.24	-103.67
Motorola Moto G4 (S)	-90.99	-95.73	-104.83	-108.66
Sony Xperia E5 (S)	-90.9	-97.39	-100.32	-108.2
Huawei GX 8 (S)	-90.35	-93.32	-104.35	-107.18
Huawei Honor 7 (S)	-89.98	-95.31	-97.61	-107.29
Huawei P10 + (S)	-89.8	-91.7	-104.8	-106.64
Alcatel POP 4+ (S)	-89.74	-94.37	-100.94	-102.18
Sony Xperia Z3 (S)	-89.7	-93.22	-104.14	-106.03
One Plus 3T (S)	-89.68	-90.22	-104.64	-107.21
Doro Liberto 825 (S)	-89.59	-92.35	-101.69	-103.57
Sony Xperia X (S)	-89.43	-95.12	-104.04	-106.28
HTC One M8s (S)	-89.14	-94.35	-104.14	-106.8
Huawei Mate 9 (S)	-88.72	-94.15	-105.68	-106.6
HTC 10 (S)	-88.47	-92.08	-100.54	-106.3
Google Pixel XL (S)	-88.4	-90.44	-103.56	-103.97
Alcatel Idol 4 (S)	-87.91	-93.57	-103.73	-105.42
Sony Xperia XA (S)	-87.75	-96.59	-101.04	-110.6
HTC One (S)	-87.63	-92.63	-101.37	-106.67
Apple iPhone 6 (S)	-87.52	-93.02	-102.12	-106.9
Google Pixel (S)	-87.5	-93.49	-102.16	-104.71
LG G6 (S)	-87.39	-95.81	-105.04	-108.61
Apple iPhone 6s+ (S)	-86.77	-95.44	-105.13	-104.72
Motorola Moto E3 (S)	-86.45	-91.49	-99.45	-100.11
Xiaomi Mi Note 2 (S)	N/A	-94.35	-104.8	-106.8
Xiaomi Mi5s (S)	N/A	-94.9	-102.93	-106.58
Alcatel 2045 (F)	N/A	N/A	-104.76	-105.79
Alcatel Pixi 4 (4G) (S)	N/A	N/A	-103.7	-103.63
Alcatel Pixi 4(3G) (S)	N/A	N/A	-102.75	-103.5
Doro PhoneEasy 631 (F)	N/A	N/A	-105.32	-107.61
Huawei Y3 (S)	N/A	N/A	-100.23	-106.73
Motorola Moto E (S)	N/A	N/A	-105.39	-108.73
Samsung Galaxy J1 (S)	N/A	N/A	-101.3	-102.97
Vodafone Smart First 7 (S)	N/A	N/A	-105.26	-105.19

Mobile Handset	LTE- 800	LTE - 1800	UMTS- 900	UMTS -2100
Nokia 130 (F)	N/A	N/A	N/A	N/A
Nokia 3310 (F)	N/A	N/A	N/A	N/A
Nokia 222 (F)	N/A	N/A	N/A	N/A
Alcatel 1016 (F)	N/A	N/A	N/A	N/A

TIS Measurements for HL Scenario

2.11 Table 4 sets out the TIS measurements for the HL scenario (handset in left hand held) for all 71 handsets in the LTE - 800³⁴, LTE- 1800³⁵, UMTS 900³⁶ and UMTS 2100³⁷ bands where applicable³⁹. The handsets are listed in decreasing order of TIS measurements in the LTE - 800 band.

Table 4: TIS (dBm) for the HL scenario in the LTE - 800 band in decreasing order of sensitivity

***F – Feature Phone, *S – Smart Phone**

Mobile Handset	LTE- 800	LTE - 1800	UMTS- 900	UMTS -2100
HTC Desire 530 (S)	-97.56	-97.52	-106.41	-109.74
Huawei P9 Lite (S)	-95.38	-95.8	-106.95	-107.64
Huawei P10 (S)	-94.89	-95.39	-106.81	-106.95
Samsung Galaxy J3 (S)	-94.65	-93.83	-106.39	-106.57
Microsoft Lumia 550 (S)	-94.11	-94.88	-105.53	-107.26
Samsung Galaxy S8 (S)	-93.9	-96.54	-105.92	-106.59
Samsung Galaxy S6 Edge (S)	-93.71	-94.55	-104.28	-105.69
Samsung Galaxy A3 (S)	-93.55	-96.8	-105.47	-107.88
Microsoft Lumia 650 (S)	-93.37	-93.39	-105.78	-106.3
Huawei Y6 (S)	-93.2	-95.14	-102.7	-105.89
Samsung Galaxy S6 (S)	-93.08	-95.54	-104.22	-108.73
HTC Desire 825 (S)	-93.05	-97.09	-106.51	-109.84
Samsung Galaxy S7	-93.01	-97.06	-106.07	-107.52
Apple iPhone 7+ (S)	-92.96	-92.97	-105.17	-104.68
Samsung Galaxy S8+ (S)	-92.95	-96.54	-107.19	-106.39
Microsoft Lumia 640 (S)	-92.77	-94.36	-104.8	-105.84
Samsung Galaxy Note5 (S)	-92.55	-95.66	-105.91	-106.38
Vodafone Smart Ultra 7 (S)	-92.53	-96.55	-105.99	-102.83
Sony Xperia XZ (S)	-92.39	-95.74	-113.13	-107.39
Apple iPhone 7 (S)	-92.17	-95.51	-102.72	-106.11
Huawei Honor 8 (S)	-92.14	-94.34	-104.33	-107.33
Huawei Mate S (S)	-92.07	-91.14	-104.25	-102.34
Sony Xperia M4 (S)	-92.05	-96.37	-104.64	-108.82
Microsoft Lumia 950 (S)	-91.93	-94.74	-101.9	-105.75
Huawei Honor 8 Pro (S)	-91.83	-90.88	-106.51	-103.27
Sony Xperia E5 (S)	-91.52	-97.31	-100.31	-108.12
Samsung Galaxy S7 Edge (S)	-91.45	-97.12	-105.26	-107.55
Huawei P9 (S)	-91.39	-93.49	-105.96	-106.26
Samsung Galaxy S5 mini (S)	-91.34	-96.44	-101.52	-104.93
Huawei Y5 (S)	-91.08	-96.75	-103.68	-107.83

³⁹ Some of the 71 mobile handsets that may support voice functionality do not have data functionality

Mobile Handset	LTE- 800	LTE - 1800	UMTS- 900	UMTS -2100
Samsung Galaxy J5 (S)	-90.94	-94.67	-104.89	-104.58
LG G6 (S)	-90.75	-95.29	-104.88	-108.26
Alcatel Pop 4+ (S)	-90.56	-92.98	-101.93	-104.83
Sony Xperia X (S)	-90.41	-93.95	-104.09	-106.34
Apple iPhone SE (S)	-90.27	-94.71	-102.07	-103.72
Vodafone Smart Turbo 7 (S)	-90.27	-95.22	-103.37	-105.72
Huawei P10 + (S)	-90.08	-93.06	-105.73	-105.24
Apple iPhone 5s (S)	-90.02	-95.38	-102.58	-104.49
Motorola Moto G4 (S)	-90.01	-95.06	-104.9	-108.36
Huawei Mate 9 (S)	-89.79	-93.79	-106.52	-106.02
HTC One M8s (S)	-89.75	-91.28	-102.08	-102.23
Doro Liberto 825 (S)	-89.42	-92.63	-102.51	-103.54
One Plus 3T (S)	-89.35	-91.38	-103.99	-107.91
Google Pixel (S)	-89.32	-93.49	-102.27	-106.64
Motorola Moto G (3rd Gen)(S)	-89.32	-95.37	-104.04	-108.18
Apple iPhone 6s (S)	-89.19	-95.78	-103.19	-108.27
HTC 10 (S)	-89.07	-87.53	-100.79	-102.83
Alcatel Idol 4 (S)	-88.86	-93.52	-104.73	-105.91
Google Pixel XL (S)	-88.73	-93.01	-103.63	-105.17
Sony Xperia XA (S)	-88.62	-95.99	-101.03	-110.28
Huawei Honor 7 (S)	-88.27	-95.29	-111.17	-106.73
Sony Xperia Z3 (S)	-88.26	-91.6	-102.48	-105.76
Huawei GX 8 (S)	-87.27	-93.24	-101.53	-107.05
Apple iPhone 6s+ (S)	-86.8	-95.4	-103.76	-106.14
HTC One M8s (S)	-86.64	-91.46	-99.59	-106.92
Motorola Moto E3 (S)	-86.25	-92.59	-95.41	-100.32
Apple iPhone 6 (S)	-82.62	-94.09	-97.71	-106.42
Xiaomi Mi Note 2 (S)	N/A	-93.57	-105.45	-106.75
Xiaomi Mi5s (S)	N/A	-92.86	-105.37	-103.5
Alcatel 2045 (F)	N/A	N/A	-104.39	-105.96
Alcatel Pixi 4(4G)	N/A	N/A	-101.85	-103.3
Alcatel Pixi 4(3G)	N/A	N/A	-101.38	-102.96
Doro PhoneEasy 631 (F)	N/A	N/A	-106.4	-107.71
Huawei Y3 (S)	N/A	N/A	-102.01	-105.74
Motorola Moto E (S)	N/A	N/A	-105.51	-108.79
Samsung Galaxy J1 (S)	N/A	N/A	-98.09	-104.47
Vodafone Smart First 7 (S)	N/A	N/A	-105.14	-107.14
Nokia 130 (F)	N/A	N/A	N/A	N/A
Nokia 3310 (F)	N/A	N/A	N/A	N/A
Nokia 222 (F)	N/A	N/A	N/A	N/A
Alcatel 1016 (F)	N/A	N/A	N/A	N/A

2.3 SUMMARY

2.12 The TIS measurements obtained by ComReg are broadly in line with comparable measurements produced and previously published by Aalborg University which, in a series of studies supported by the Nordic Council of Ministers, measured the antenna performance of a number of mobile phones widely used in the Nordic Countries.⁴⁰

2.13 The following points can be made concerning the TIS measurements obtained by ComReg, for the LTE 800, LTE 1800, UMTS 900 and UMTS 2100 bands:

2.14 LTE 800 band (Band 20):

- for the HR scenario, average TIS was - 91.3 dBm and the difference between the highest and lowest TIS measurements was 9.8 dB;
- for the HL scenario, average TIS was -91.0 dBm and the difference between the highest and lowest TIS measurements was 14.9 dB; and

2.15 LTE 1800 band (Band 3):

- for the HR scenario, average TIS was -94.3 dBm and the difference between the highest and lowest TIS measurements was 7.6 dB; and
- for the HL scenario, average TIS was – 94.5 dBm and the difference between the highest and lowest TIS measurements was 10 dB;

2.16 UMTS 2100 band (Band 1):

- for the HR scenario, average TIS was -106.3 dBm and the difference between the highest and lowest TRP measurements was 10.5 dB; and
- for the HL scenario, average TIS was -106.2 dBm the difference between the highest and lowest TIS measurements was 10 dB;

2.17 UMTS 900 band (Band 8):

- for the HR scenario, average TIS was -104 dB and the difference between the highest and lowest TRP measurements was 10.5 dB; and
- for the HL scenario, average TIS was -104.1 dBm the difference between the highest and lowest TIS measurements was 17.7 dB;

⁴⁰ <https://www.pts.se/upload/Rapporter/Tele/2016/MobilephoneTest2016-augusti-2016.pdf>
https://ens.dk/sites/ens.dk/files/Tele/mobile_phone_antenna_performance_2013_01.pdf

2.18 The average results of the measurements show that:

- very small variation (0.1dB to 0.3 dB) exists between HR scenario and HL scenario for all the bands.
- the average results of the measurements are above the GSMA Operator Acceptance values for TIS as set out in Table 1.

Annex: 1 Mobile Handsets Tested⁴¹

No	Mobile Handset	Width (mm)	Hand Type
1	Alcatel 1016	< 56	Monoblock
2	Alcatel 2045	< 56	PDA
3	Alcatel Idol 4 VR Edition	73	UW-PDA
4	Alcatel Pixi 4 (3G)	66	PDA
5	Alcatel Pixi 4 (4)	65	PDA
6	Alcatel POP 4 Plus	77	UW-PDA
7	Apple iPhone 5s	59	PDA
8	Apple iPhone 6	67	PDA
9	Apple iPhone 6s	67	PDA
10	Apple iPhone 6s+	78	UW-PDA
11	Apple iPhone 7	67	PDA
12	Apple iPhone 7+	78	UW-PDA
13	Apple iPhone SE	59	PDA
14	Doro Liberto 825	73	UW-PDA
15	Doro PhoneEasy 631	53	PDA
16	Google Pixel	69	PDA
17	Google Pixel XL	76	UW-PDA
18	HTC 10	72	UW-PDA
19	HTC Desire 530	71	UW-PDA
20	HTC Desire 825	77	UW-PDA
21	HTC One A9	71	UW-PDA
22	HTC One M8s	71	UW-PDA
23	Huawei GX8	77	UW-PDA
24	Huawei Honor 7	72	UW-PDA
25	Huawei Honor 8	71	UW-PDA
26	Huawei Honor 8 Pro	78	UW-PDA
27	Huawei Mate 9	79	UW-PDA
28	Huawei Mate S	75	UW-PDA
29	Huawei P10	69	PDA
30	Huawei P10+	74	UW-PDA
31	Huawei P9	71	UW-PDA
32	Huawei P9 Lite	73	UW-PDA
33	Huawei Y3	64	UW-PDA
34	Huawei Y5	72	UW-PDA
35	Huawei Y6	72	UW-PDA
36	LG G6	72	UW-PDA
37	Microsoft 550	68	PDA

⁴¹ Some of the 71 mobile handsets do not have data functionality.

No	Mobile Handset	Width (mm)	Hand Type
38	Microsoft 640	72	UW-PDA
39	Microsoft 650	71	UW-PDA
40	Microsoft 950	73	UW-PDA
41	Motorola Moto E	65	PDA-Grip
42	Motorola Moto E3	72	UW-PDA
43	Motorola Moto G (3rd Gen)	72	UW-PDA
44	Motorola Moto G4	76	UW-PDA
45	Nokia 130	< 56	Monoblock
46	Nokia 222	< 56	Monoblock
47	Nokia 3310	< 56	Monoblock
48	OnePlus 3T	75	UW-PDA
49	Samsung Galaxy A3	66	PDA
50	Samsung Galaxy J1	68	PDA
51	Samsung Galaxy J3	70	PDA
52	Samsung Galaxy J5	72	UW-PDA
53	Samsung Galaxy Note 5	76	UW-PDA
54	Samsung Galaxy S5 Mini	64	PDA
55	Samsung Galaxy S6	71	UW-PDA
56	Samsung Galaxy S6 edge	70	PDA
57	Samsung Galaxy S7	70	PDA
58	Samsung Galaxy S7 edge	73	UW-PDA
59	Samsung Galaxy S8	68	PDA
60	Samsung Galaxy S8+	73	UW-PDA
61	Sony Xperia E5	69	PDA
62	Sony Xperia M4	73	UW-PDA
63	Sony Xperia X	69	PDA
64	Sony Xperia XA	67	PDA
65	Sony Xperia XZ	72	UW-PDA
66	Sony Xperia Z3	72	UW-PDA
67	Vodafone Smart First 7	63	PDA
68	Vodafone Smart Turbo 7	72	UW-PDA
69	Vodafone Smart ultra 7	78	UW-PDA
70	Xiaomi Mi Note 2	78	UW-PDA
71	Xiaomi Mi5s	70	PDA

Annex: 2 Standards and Measurement Techniques

A 2.1 Determining the radio performance of mobile handsets is important and various organisations have worked on terminal antenna measurements in recent years. These include the Cellular Telephone Industries Association (CTIA), Cooperation in Science and Technology (COST), and 3rd Generation Partnership Project (3GPP). Below are brief descriptions of these organisations and the measurement techniques standardised over the years⁴².

CTIA

A 2.2 The CTIA is an international industry trade group representing the wireless communications sectors, including cellular, and its test procedures are widely used and accepted by the mobile communications industry. The CTIA has defined a common set of industry-standard test procedures called OTA performance measurements^{43 44} through which the Radiated RF Power and Receiver Performance measurements on wireless devices are evaluated. This CTIA test procedures define general requirements for equipment configuration, laboratory techniques, test methodologies, and evaluation criteria that must be met in order to ensure the accurate, repeatable, and uniform testing of wireless devices, to CTIA Certification standards.

A 2.3 The current CTIA certification includes most of the 3GPP technical specifications for UMTS mobile handsets. According to CTIA, two methods are standardized for measuring the performance of mobile handset antennas, executed both in free space and in the presence of the head, body and hand. The two methods are the conical cut method and the great circle cut method. These are 3D pattern measurement methods and, with modifications, they can be implemented in an anechoic chamber with either a spherical scanning or a dual axis measurement system, in accordance with 3GPP. The values measured (the “figures of merit”) using the great circle cut method and conical cut method are TRP and TIS.

⁴² Over-The-Air Performance Estimation of Wireless Device Antennas - SATHYAVEER PRASAD;2013

⁴³ CTIA Test plan for wireless device over the air performance.

⁴⁴ A CTIA approved antenna measurement system for over-the-air testing of wireless devices - B. Lawrence; ETS-LINDGREN, UK; 2004.

3GPP⁴⁵ ⁴⁶

A 2.4 The 3rd Generation Partnership Project (3GPP) brings together seven telecommunications standard development organizations - ARIB, ATIS, CCSA, ETSI, TSDSI, TTA, and TTC.

A 2.5 The original scope of 3GPP (1998) was to produce Technical Specifications and Technical Reports for a 3G Mobile System based on evolved GSM core networks and the radio access technologies that they support (i.e. Universal Terrestrial Radio Access (UTRA) both Frequency Division Duplex (FDD) and Time Division Duplex (TDD) modes).

A 2.6 The scope was subsequently amended to include the maintenance and development of the Global System for Mobile communication (GSM) Technical Specifications and Technical Reports including evolved radio access technologies (e.g. General Packet Radio Service (GPRS) and Enhanced Data rates for GSM Evolution (EDGE)). The term "3GPP specification" covers all GSM (including GPRS and EDGE), W-CDMA (including HSPA) and LTE (including LTE-Advanced and LTE-Advanced Pro) specifications. The following terms are also used to describe networks using the 3G specifications: UTRAN, UMTS (in Europe) and FOMA (in Japan).

A 2.7 The 3GPP technical specification groups that work with terminal testing and mobile terminal conformance testing are the GSM EDGE Radio Access Network Working Group 3 (GERAN WG3) and the Radio Access Network Working Group 5 (RAN WG5), respectively. The Radio Access Network Working Group 4 (RAN WG4) works with "radio performance and protocol aspects (system) - RF parameters and BS conformance." This group contributes to the standardisation of the figures of merit required for estimating the radio performance of mobile handset antennas.

A 2.8 The 3GPP standard procedure for measuring the radio performance of 3G, UMTS and GSM mobile handsets is based on the procedure proposed by COST 273 SWG 2.2. According to this, the standard procedure for measuring the radio performance of the transmitter and receiver must include the antenna and the effects of the user. In this context, two measurement procedures were standardised, the Spherical scanning system and Dual axis system.

⁴⁵ 3GPP Scope and Objectives – 3GPP; 2007.

⁴⁶ Over-The-Air Performance Estimation of Wireless Device Antennas - SATHYAVEER PRASAD;2013.

A 2.9 Both procedures are based on the 3D pattern measurement method, proposed by COST 259⁴⁷ and COST 273⁴⁸, and are carried out in an anechoic chamber. Under the 3GPP standard, utilising a reverberation chamber is considered an alternative procedure for measuring the TRP of mobile handsets. The 3GPP has defined the reverberation chamber and anechoic chamber two-stage and multi-probe test methods as standard methods for MIMO Over the Air testing.

A 2.10 The TRP and TIS are the standard figures of merit for estimating the radio performance of a mobile handset antenna, in an isotropic field distribution environment with a cross polarisation ratio of unity.

Measurement Techniques⁴⁹

A 2.11 The performance of Handset under Test (HUT) can be determined by characterising the Far-Field (FF) radiation. There are two measurement systems capable of providing the Far Field radiation characteristics, directly or indirectly.

Direct Measurement Techniques⁵⁰

A 2.12 Direct measurement techniques are based on the Far-Field measurement systems. In direct measurement techniques, the distance L between the probe and the HUT has to be great enough to consider that the HUT is in the plane wave region and this could be considered as a disadvantage of the direct measurement technique as it could require a large distance. The sub-categories of direct measurement techniques are outdoor FF range, indoor FF range, and compact range.

Indirect Measurement Techniques⁵¹

A 2.13 Indirect measurement techniques are based on Near-Field (NF) measurement systems. Once the Near-Field measurements are captured they can then be mathematically transformed to Far-Field radiation with NF/FF algorithms. Indirect measurement techniques can be split in three sub-categories- planar, cylindrical and spherical geometries.

A 2.14 The StarLab system is a Near Field multi-probe system which can be configured either in cylindrical or in spherical geometry as configured for this measurement study. Compared to FF the advantage of NF is the reduced distance between HUT and probes.

⁴⁷ COST Action 259 - Wireless Flexible Personalized Communications – COST; 1996

⁴⁸ COST Action 273 - Towards Mobile Broadband Multimedia Networks - COST; 2005

⁴⁹ User Guide – StarLab - MVG; 2015

⁵⁰ User Guide – StarLab - MVG; 2015

⁵¹ User Guide – StarLab - MVG; 2015

A 2.15 In spherical NF measurements, the electromagnetic field is sampled on a closed sphere surface surrounding the antenna under test during its rotation and then transformed to FF by Fourier transformation algorithms based on the Huygens principle. Spherical scanning measurement is suitable for mobile handset testing because it is accurate and cost efficient. Spherical scanning is used for Omni-directional antennas, semi-directive antennas or directive antennas.

Dual axis system

A 2.16 A dual axis system is a method where the mobile handset is placed on a positioner that is able to rotate around two different axes. The signal is transmitted/received by a fixed probe antenna.

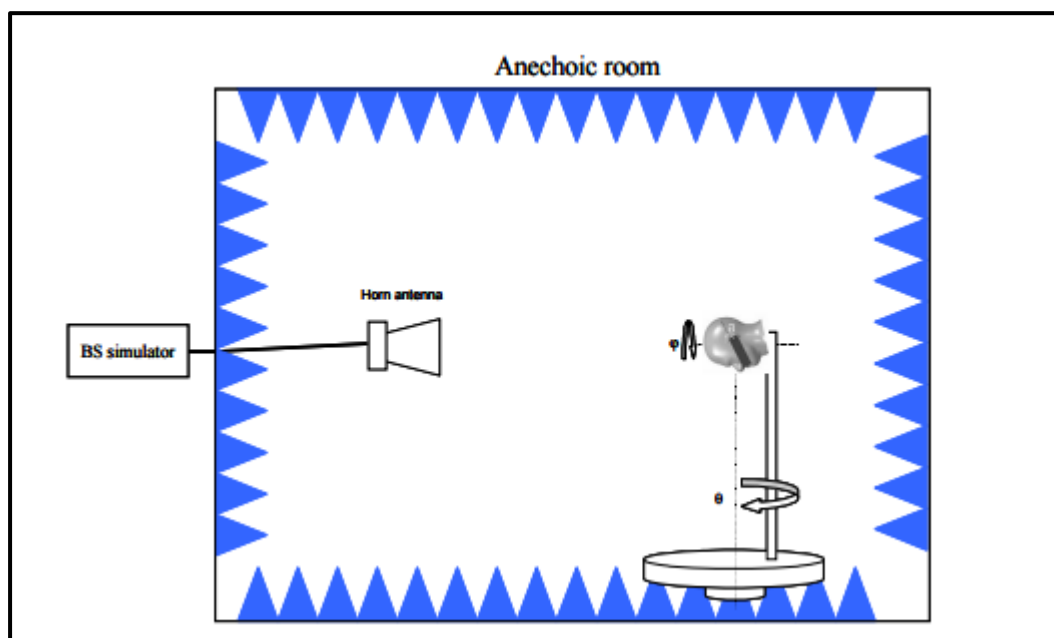

Figure 3: Dual axis system

Spherical Scanning Measurement methods

A 2.17 A spherical scanner system is a method where the mobile handset is placed on a positioner that is capable of rotating horizontally. The probe antenna is then rotated physically along the vertical plane in order to get the 3D pattern of the mobile handset under test. Spherical Scanning systems can also use multi-probe antennas where these antennas can be placed along an arch in vertical plane and electronically switched in order to get the 3D pattern.

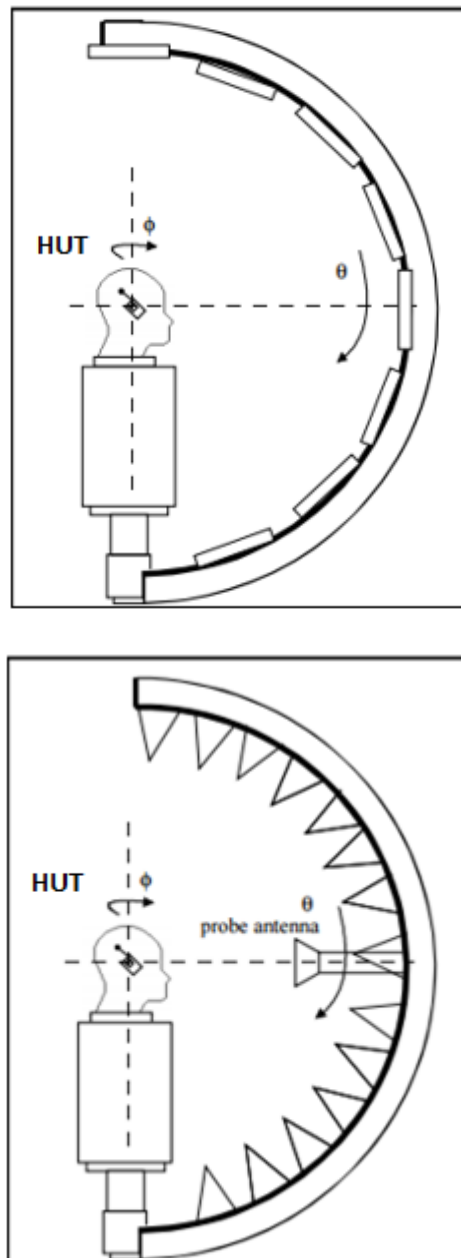

Figure 4: (a) Multi Probes (b) Single Probe

A 2.18 The spherical scanning measurement is one of the indirect measurement techniques (NF) to determine FF radiation characteristics of antennas. Within the spherical scanning technique there are two acceptable methods of scanning the HUT to determine figures of merit such as TRP and TIS. These methods are the conical cut method and the great circle cut method.

A 2.19 **The conical cut method:** The handset under test rotates on its long axis and the measurement antenna is selected electrically above and below the level of the handset under test for each rotation.

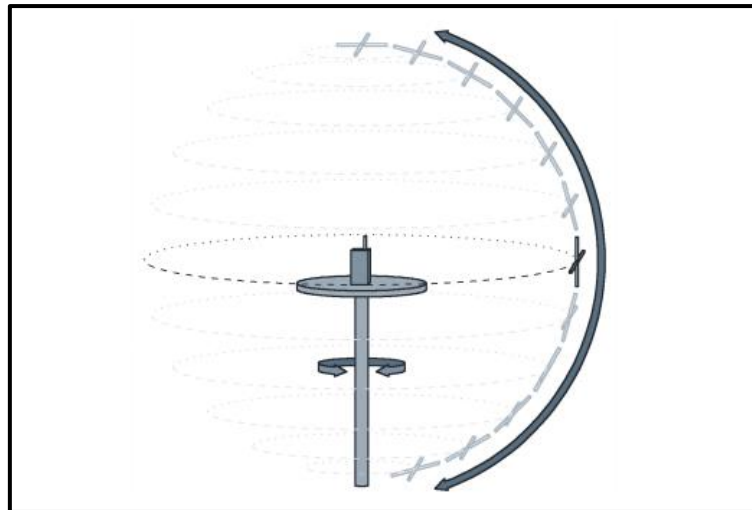

Figure 5: The conical cut method

A 2.20 **The great circle cut method:** for this method, the measurement antenna remains fixed and the handset under test is rotated about two axes in sequential order.

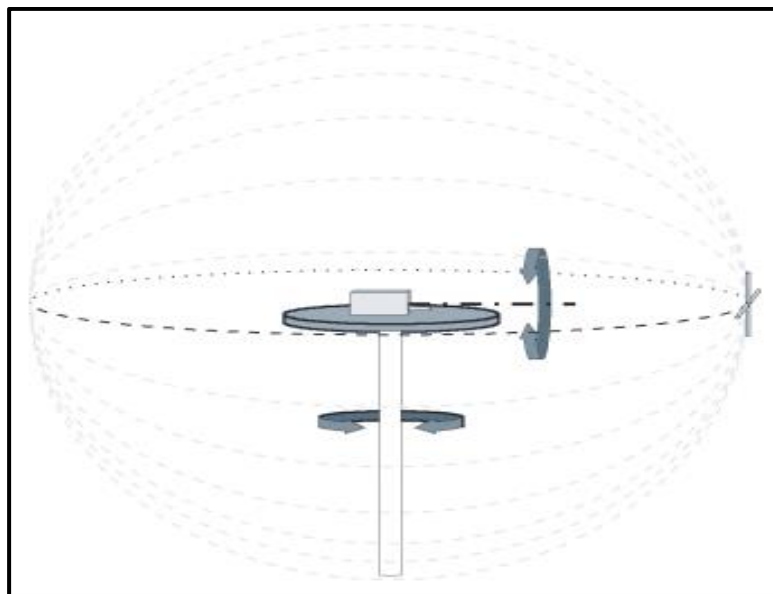

Figure 6: The great circle cut method

The spherical scanning measurement is defined by both CTIA and 3GPP as the standard reference test method for measuring the performance of the HUT. The StarLab used for testing is based on the great circle cut method. In both methods, the angle of elevation in the long axis of HUT is the Theta (θ), and the azimuth angle of the HUT is the Phi (ϕ). At all times reference must be made to the maximum size of the handset under test so that the StarLab near to far field transformation integrity is adhered to, see Table 5

Table 5: Maximum diameter of HUT⁵²

Frequency (GHz)	NUMBER OF OVERSAMPLING				
	x 1	x 2	x 3	x 5	x10
0.65	0.45	0.45	0.45	0.45	0.45
1	0.45	0.45	0.45	0.45	0.45
2	0.38	0.45	0.45	0.45	0.45
3	0.25	0.45	0.45	0.45	0.45
4	0.19	0.38	0.45	0.45	0.45
5	0.15	0.31	0.45	0.45	0.45

Table 6: System specifications⁵³

PEAK GAIN ACCURACY	
0.65 GHz - 0.8 GHz	±1.5 dB
0.8 GHz - 1 GHz	±1.1 dB
1 GHz - 6 GHz	±0.8 dB

Table 7: OTA performance measurement specifications⁵⁴

ACCORDING TO CTIA SPECIFICATIONS	
TIS accuracy free space	<±2.0 dB
TIS accuracy talk position	<±2.1 dB
TIS repeatability	±0.5 dB

⁵² http://www.uwave.com.my/wp-content/uploads/2014/04/starlab_2014.pdf

⁵³ User Guide – StarLab - MVG; 2015

⁵⁴ User Guide – StarLab - MVG; 2015

Annex: 3 Test Setup and Equipment

A 3.1 The mobile handsets measured for TIS were placed in an anechoic chamber and the test equipment used is listed below and it was set up as illustrated in Figure 7

Equipment /Software used	Manufacturer	Model No/Version
Anechoic Chamber	Rainford EMC systems	-
StarLab	MVG	SL V2_0.4-6/6-18 GHz
Radio Communications Tester	Anritsu	MT8820C
Vector Network Analyser	Anritsu	MS46522B
TX Amplification Unit	MVG	1101252-2239
RX Amplification Unit	MVG	1101238-2247
Active Switching Unit	MVG	11017004-2248
Transfer Switching Unit	MVG	1101248-2235
SAM	IndexSAR	IXB-030
SatEnv	MVG	3.0.3.0
Wave Studio	MVG	1.6
CTIA ‘UWPDA’ phantom right hand)	IndexSAR	IXB-056R
CTIA ‘UWPDA’ phantom left hand	IndexSAR	IXB-056L
CTIA ‘Monoblock’ phantom right hand	IndexSAR	IXB-050R
CTIA ‘Monoblock’ phantom left hand	IndexSAR	IXB-050L
CTIA ‘Fold’ phantom right hand	IndexSAR	IXB-051R
CTIA ‘Fold’ phantom left hand	IndexSAR	IXB-051L
CTIA ‘PDA’ phantom right hand	IndexSAR	IXB-053R
CTIA ‘PDA’ phantom left hand	IndexSAR	IXB-053L
Handset alignment tool ‘A’	IndexSAR	IXJ-020
Handset alignment tool ‘B’	IndexSAR	IXJ-030
Head/Hand fixture to meet the requirements of CTIA Test Plan Satimo mounting for IndexSAR SAM head	IndexSAR	IXBH-061A

Table 8: Measurement Equipment

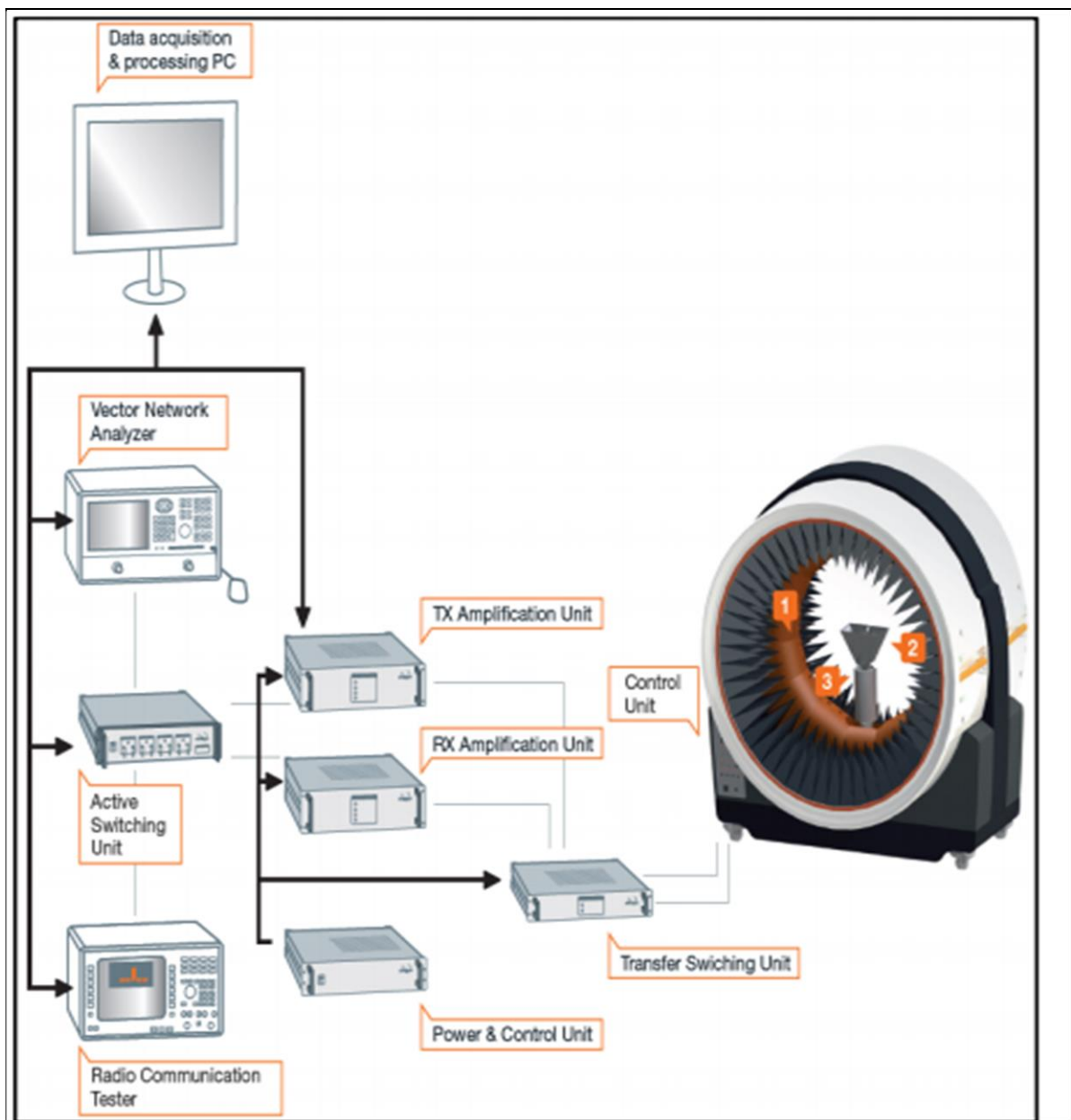

Figure 7: – StarLab Test Setup

List of Abbreviations

Abbreviation	Explanation	
dB	Decibels	
	Decibels is a ratio which describes change in signal strength	
	Decibels	
	Change in signal factor	
	0 dB	= x 1
	3 dB	= x 2
	6 dB	= x 4
10 dB	= x 10	
20 dB	= x 100	
dBm	Abbreviation for Decibels relative to one milliwatt	
2G	Second-Generation Cellular Technology	
3D	Three-Dimensional Space	
3G	Third-Generation Cellular Technology	
3GPP	3 rd Generation Partnership Project	
4G	Fourth Generation Cellular Technology	
HL	Hand Left	
HR	Hand Right	
COST	Co-operation in Science & Technology	
CTIA	Cellular Telephone Industries Association	
DL	Downlink	
EC	European Commission	
E-UTRA	Evolved Universal Terrestrial Radio Access	
FDD	Frequency Division Duplexing	
FF	Far-Field	
FS	Free Space	
GPRS/EDGE	General Packet Radio Service/Enhanced Data Rates for Global Evolution	
GSM	Global System for Mobile Communications	
GSMA	GSM Association	
GPRS	Global Packet Radio Service	
HSPA	High Speed Packet Access	
HUT	Handset Under Test	
LTE	Long Term Evolution	
MVG	Microwave Vision Group	
NF	Near-Field	
OTA	Over-the-Air	
RAN	Radio Access Network	
RCA	Radio Communications Analyser	
RF	Radio Frequency	
SAM	Specific Anthropomorphic Mannequin	
TIS	Total Isotropic Sensitivity	
TDD	Time Division Duplexing	
TRP	Total Radiated Power	

Abbreviation	Explanation
UL	Uplink
UMTS	Universal Mobile Telecommunications System
UTRAN	UMTS Terrestrial Radio Access Network
VoLTE	Voice over LTE
VoIP	Voice over Internet Protocol
VNA	Vector Network Analyser
W-CDMA	Wideband Code Division Multiple Access